



GRANADA
secondary glazing

Secondary Window Installation Manual





Index

Section 1 - General Information

- 1.1 - Pre Installation Check List
- 1.2 - Terminology
- 1.3 - Kit Form Frame Corner Cleat Assembly
- 1.4 - Kit Form Timber Subframe Assembly
- 1.5 - Kit Form Oversize Frame Joint Assembly
- 1.6 - Glazing Packer Fitting

Section 2 - Vertical Sliding Windows (BVS/TBVS)

- 2.1 - BVS / TBVS Installation
- 2.2 - BVS Through Frame Fixing Hole Positions
- 2.3 - BVS Through Frame Fixing Hole Drilling
- 2.4 - TBVS Through Frame Fixing Hole Positions
- 2.5 - TBVS Through Frame Fixing Hole Drilling
- 2.6 - BVS Balance Adjustments
- 2.7 - TBVS Balance Adjustments
- 2.8 - BVS / TBVS Post Installation Check List

Section 3 - Horizontal Sliding Windows (HS)

- 3.1 - HS Installation
- 3.2 - HS Through Frame Fixing Hole Positions
- 3.3 - HS Through Frame Fixing Hole Drilling
- 3.4 - HS Panel Installation
- 3.5 - HS Panel Alignment
- 3.6 - HS Restrictor/Anti Lift Block Installation
- 3.7 - HS Post Installation Check List

Section 4 - Hinged Units (HU-HD/HU-SL)

- 4.1 - HU-HD Installation
- 4.2 - HU-HD Through Frame Fixing Hole Positions
- 4.3 - HU-HD Through Frame Fixing Hole Drilling
- 4.4 - HU-SL Installation
- 4.5 - HU-SL Through Frame Fixing Hole Positions
- 4.6 - HU-SL Through Frame Fixing Hole Drilling
- 4.7 - HU-HD / HU-SL Post Installation Check List

Section 5 - Lift Out Windows (LO)

- 5.1 - LO Installation
- 5.2 - LO Through Frame Fixing Hole Positions
- 5.3 - LO Through Frame Fixing Hole Drilling
- 5.4 - LO Post Installation Check List



Section 1

General Information

- 1.1 - Pre Installation Check List
- 1.2 - Terminology
- 1.3 - Kit Form Frame Corner Cleat Assembly
- 1.4 - Kit Form Timber Subframe Assembly
- 1.5 - Kit Form Oversize Frame Joint Assembly
- 1.6 - Glazing Packer Fitting



Important - All defects must be reported to Granada Glazing Ltd. before installation of the product.

By commencing installation of the window, the installer has accepted that they have received the product in a satisfactory condition.

Before Unwrapping

✓

x

Is there any transit damage visible to the outer frame or panels through the wrapping Any damage must be reported to Granada Glazing Ltd. before unwrapping		
--	--	--

After Unwrapping

Is there any transit damage visible to the frame or panels		
Is there any damage or unacceptable defects to the paint finish on the frame or panels		
Is the glass free from scratches and cracks		
Is the transit strap fitted (BVS and TBVS only)		
Are all required items such as trim present		
Is colour correct		

Comments

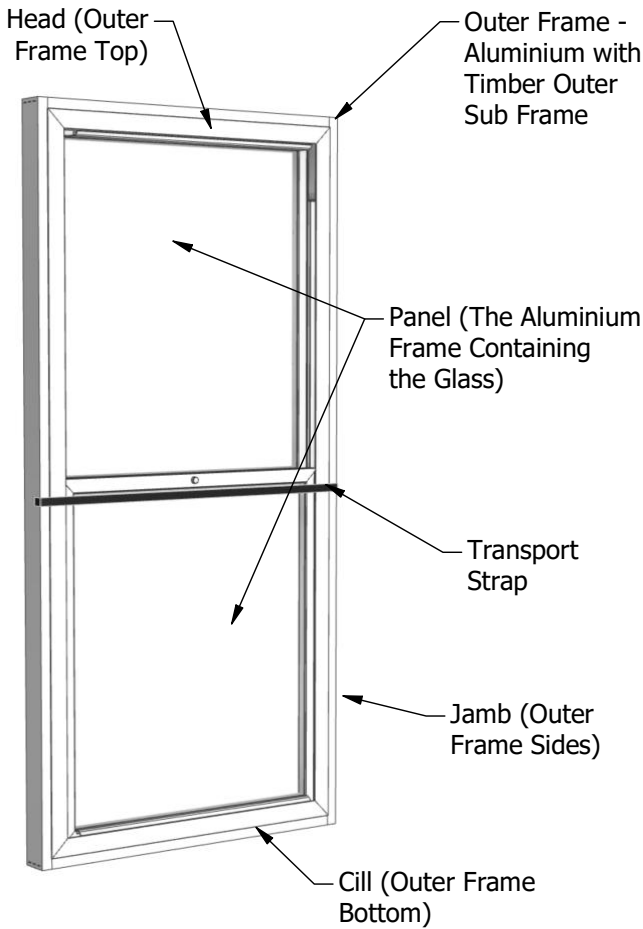

Face Fix

Face fix windows are fitted with the rear of the window in contact with an existing part of the building structure (usually the primary window). The window is then retained in position by screwing through the pre-drilled holes in the timber subframe.

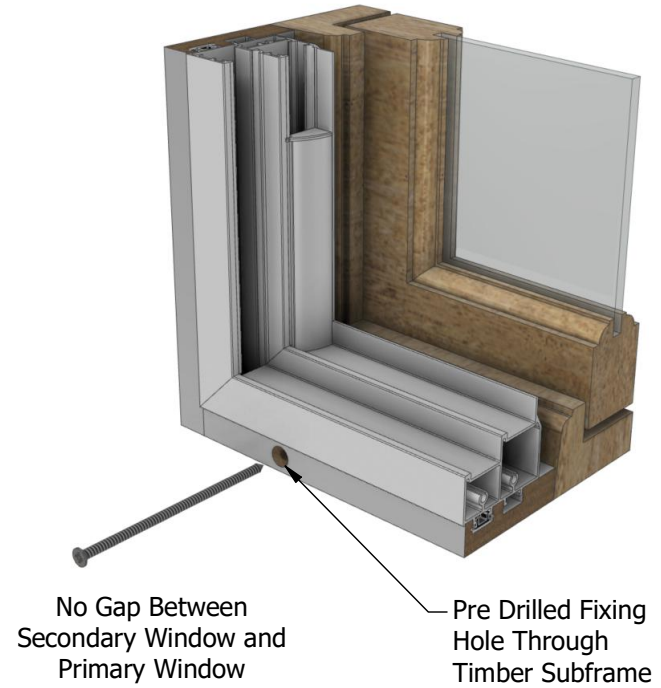

Reveal Fix

Reveal fix windows are fitted inside the window reveal (the opening in the building that the primary window is recessed into). The window is then retained in position by screwing through the pre-drilled holes in the timber subframe directly into the building substrate. This allows a larger air gap between the primary and secondary window.

Through Frame Reveal Fix

Through frame reveal fix windows are fitted inside the window reveal in a similar manner as the reveal fix windows. The main difference is that instead of fixing into the reveal through pre-drilled holes in the timber subframe, holes are drilled through the frame during installation. This process is covered in detail in the installation manual.

This allows thinner timbers to be used as they do not need to protrude past the back face of the aluminium frame.

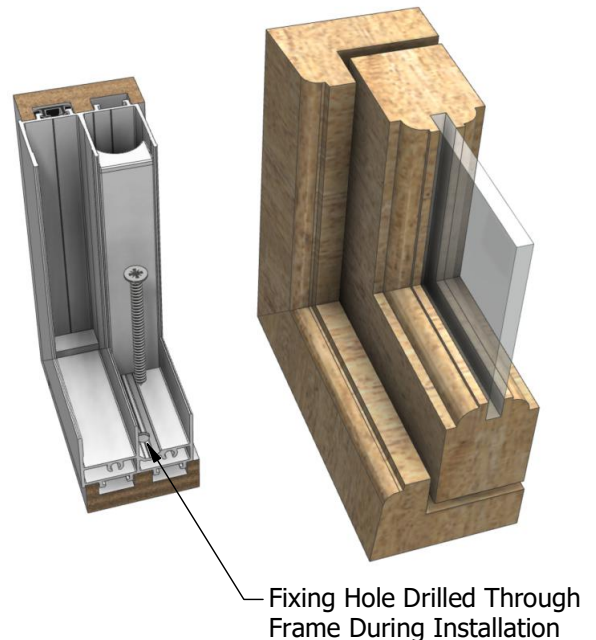
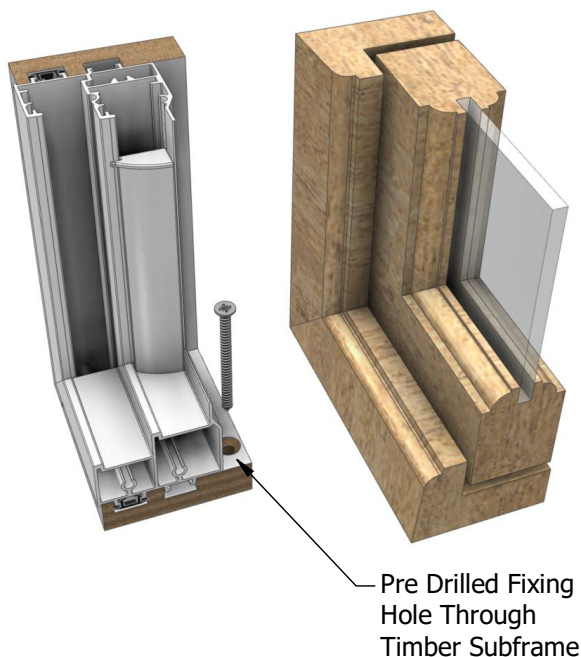



OUTER FRAME CORNER CLEATS

Note - Kit form windows are shipped with the corner cleats pre installed into two of the frame rails.

Step 1 - Align the end of the COM-Z-01 Cleats with the channels in the rails and push all four corners loosely together so that the adjacent rail faces are touching.

Note - The corner joint will look slightly misaligned at this point as shown in the image on the right. The joint will be closed at the inside with a gap at the outside.

Step 2 - Working with one corner at a time, screw the FIX-SCR-04 screws through the holes in the cleats and into the adjacent rail. Tighten the screws until the gap between the rails is closed at the front and back.

Once the gap is closed, do not continue to tighten as this will have a negative effect on the corner joint quality.

Step 1

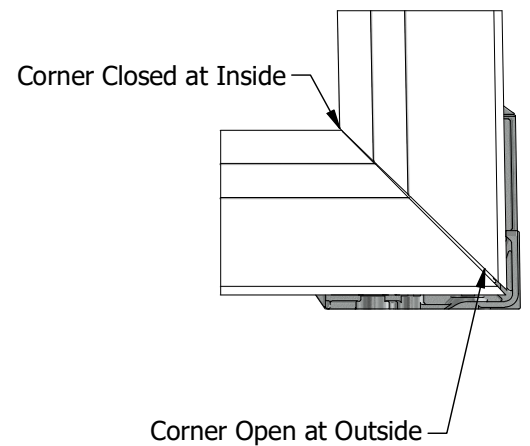
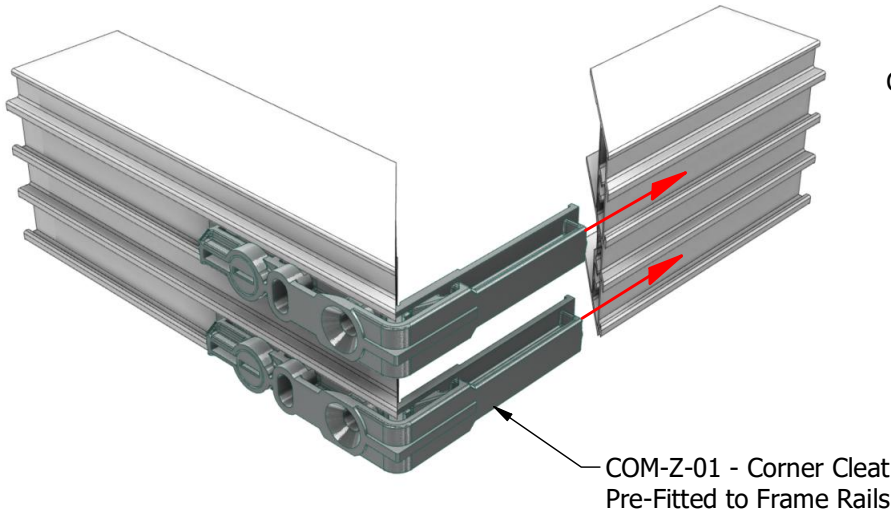

Step 2

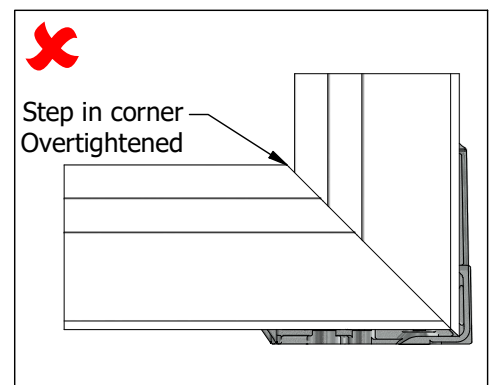
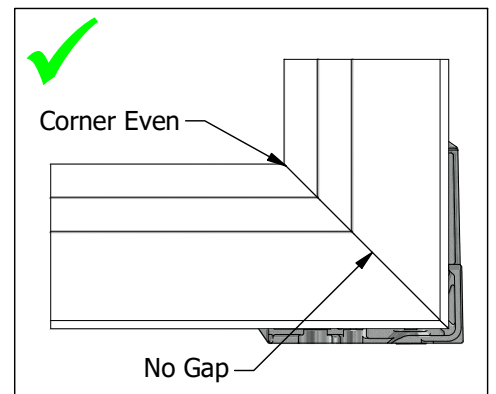
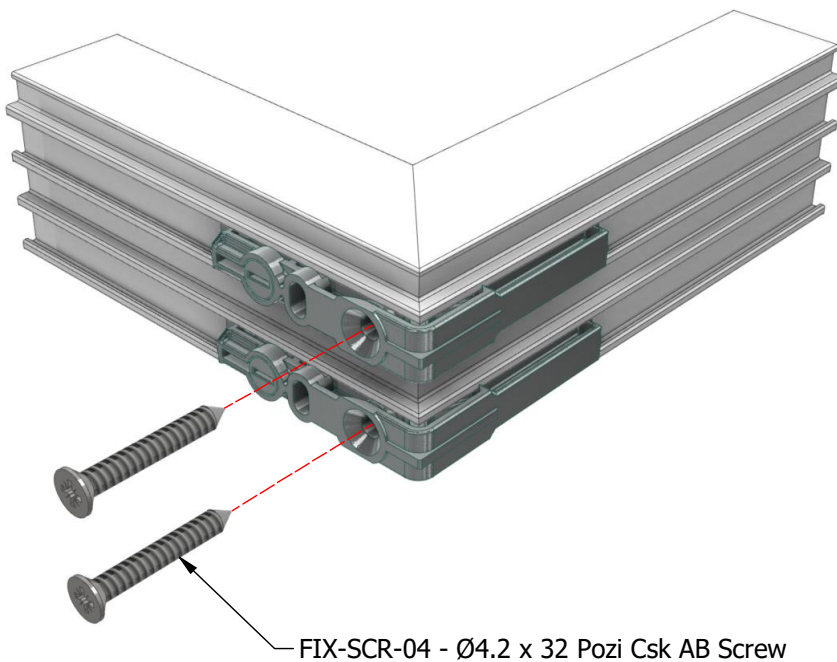



TIMBER RETENTION CLIPS

On all windows other than HS, the COM-Z-05-MOD Timber Retention Clips are only fitted to the channel furthest from the primary window side.

On HS only, the top rail should have the clips staggered between the front and rear channels. The side rails and lower rail should only be fitted to the channel furthest from the primary window side.

A clip should be fitted between 75mm and 125mm from each corner on all sides. Intermediate clips should be fitted so that there is no more than 500mm gap between adjacent clips.

The clips can be either slid in from the end of the channel prior to frame assembly on rails without pre-fitted cleats, or pressed into position.

To press fit the clips in to the channel, position them at an angle as shown, with one leg hooked under the channel leg. Starting at one end, press firmly in the position shown and work along the length of the clip until it is fully fitted in to the channel.

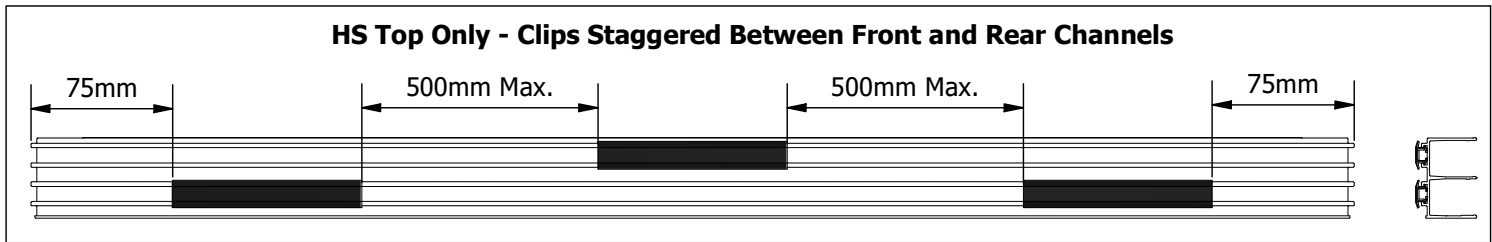
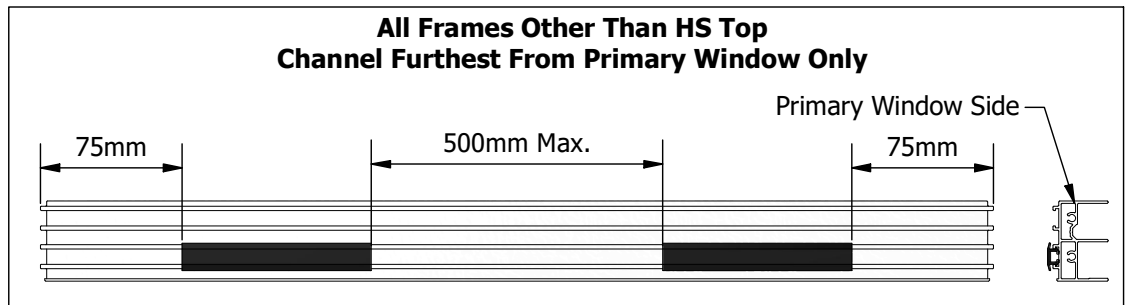
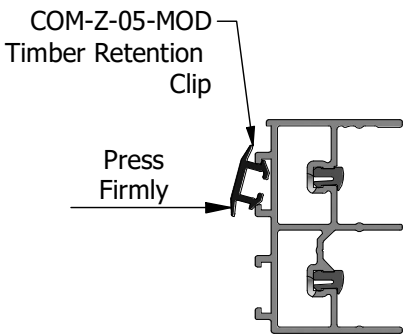

TIMBER SUBFRAME

Step 1 - Starting with the upper and lower timbers, position each timber at an angle over the clips as shown. While holding the front edge in position, twist the rear edge until the timber contacts the frame profile.

Step 2 - Check for any visible gap along the front edge in the position shown. If a gap is present it would indicate that the timber is not fully seated to its required position. If there is a visible gap use hand pressure to push the timber until it contacts the aluminium. Repeat the process with the side timbers

Step 3 - Starting at one corner, align the end of the side timber to the outside face of the adjacent timber to within $\pm 0.5\text{mm}$. Using a PZ2 bit, screw in 2x FIX-SCR-01 $\text{\O}4.2 \times 25$ Pozzi Csk Wood Screws until the timbers are joined firmly.

Important - Do not over tighten the screws as this may cause them to strip from the adjacent timber.

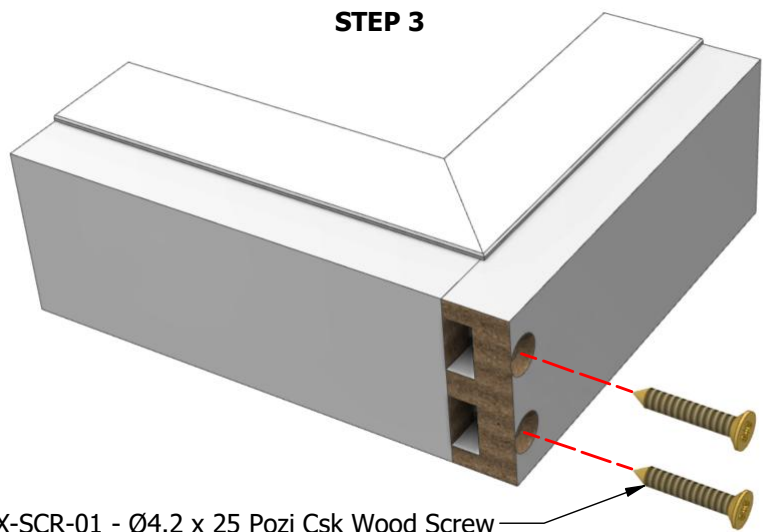
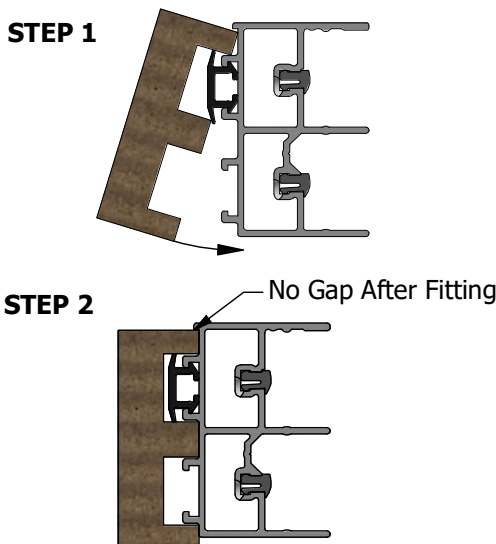



INLINE FRAME COUPLERS

STEP 1 - Insert the HDW-Z-01-MOD2 Inline Frame Couplers into the grooves on the outside of the frame profile as shown. Align the edge of the slot in the couplers with the end of the frame profile.

Tighten the M8 grub screws to fix the couplers in position in the frame profile.

STEP 2 - Push the adjacent outer frame profile over the end of the couplers until it sits fully against the first frame profile.

Double check that the outer faces align to an acceptable level and that there is no gap at the joint.

Using a flat blade screwdriver, turn the cams in the couplers 90° to lock in position. The cams have an integral stop that will prevent rotation once the correct position has been reached.

STEP 3 - If the window is a HS, check that there is no gap or significant step between the adjacent plastic track profiles.

Any gap or step could lead to premature wear of panel rollers.

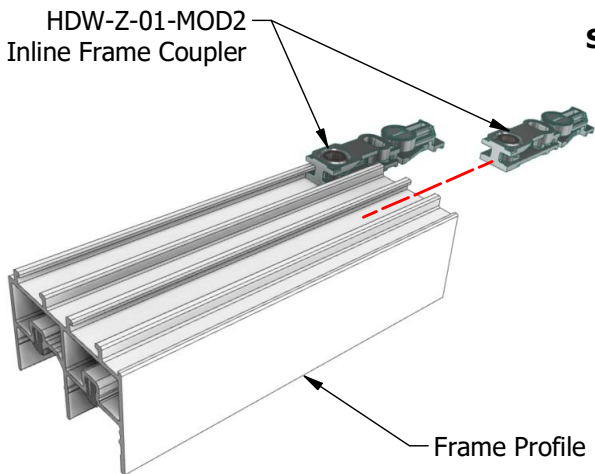

STEP 1

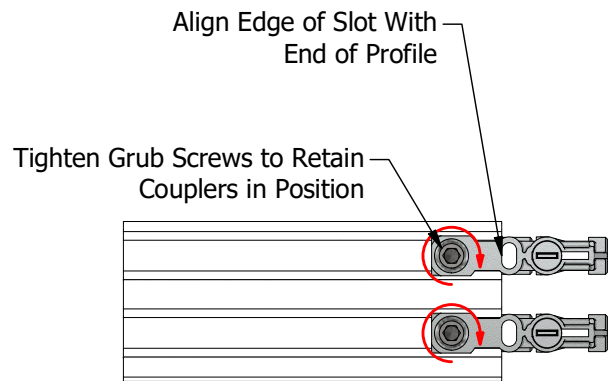

STEP 2

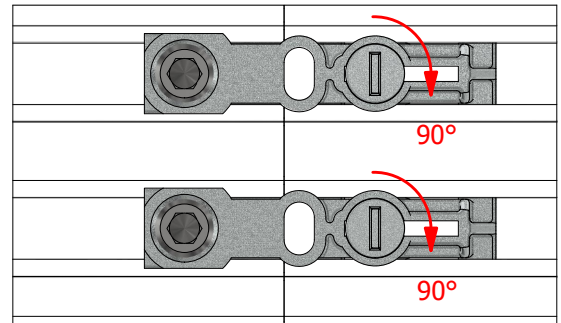
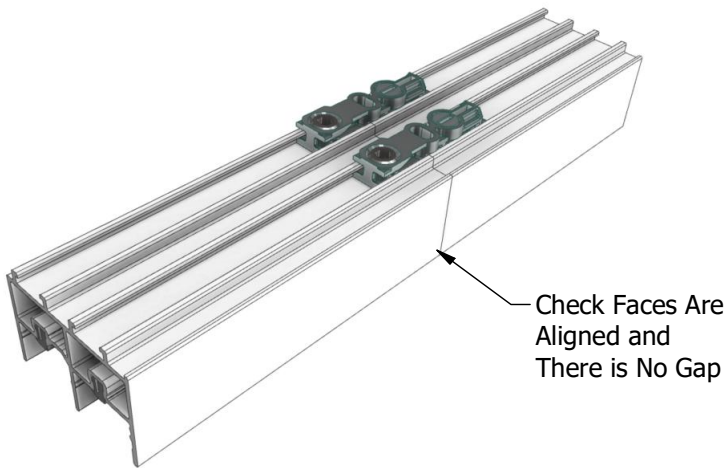

STEP 3 (HS Only)

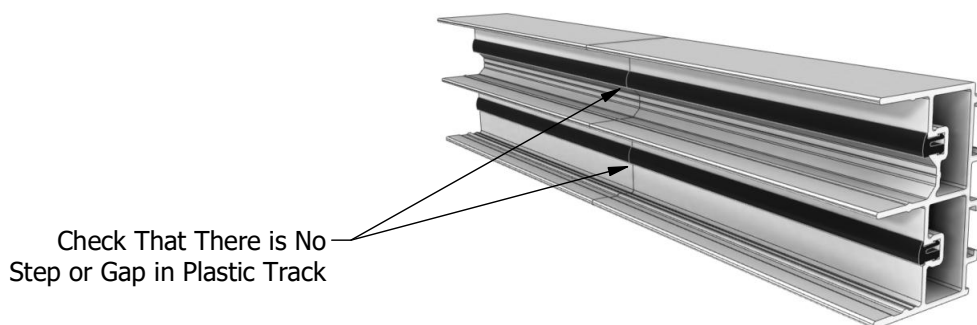



Typical Glazing Packer

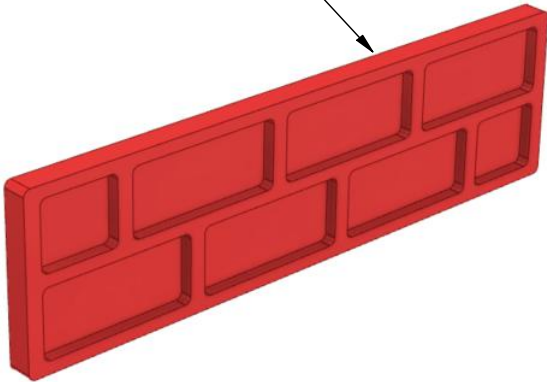

Correct packing of the outer frame in to the reveal is essential to ensure correct operation of the secondary window.

Packers must be fitted perpendicular to the face of the frame and as close to the screw fixing holes as possible. This will provide the best support for the fully installed window and prevent twisting of the outer frame.

Any glazing packers protruding from the front face of the secondary window frame must be trimmed back only after frame installation is complete.

See window specific instruction sheets for additional window location information and frame packing tolerances.

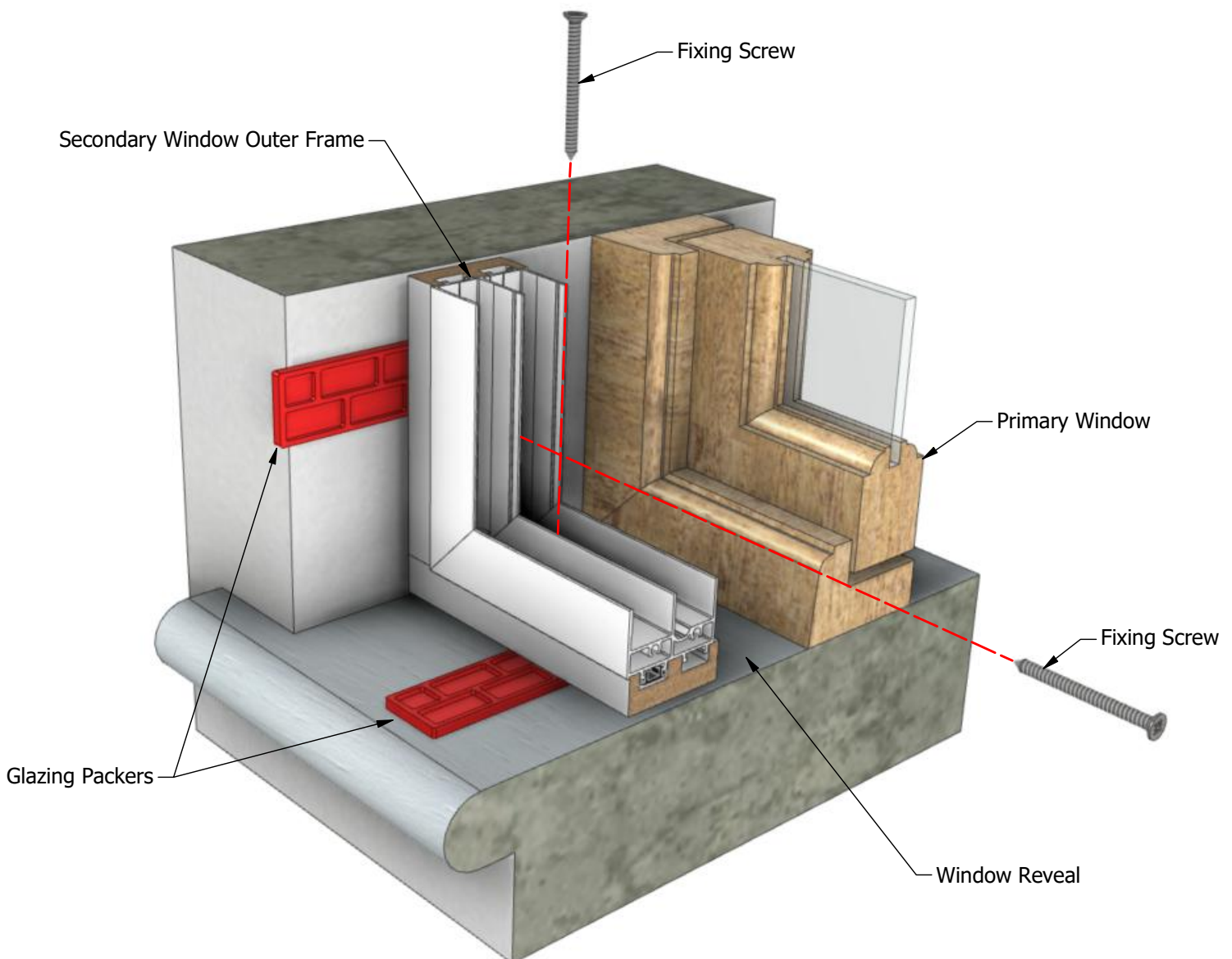



Section 2

Vertical Sliding Windows (BVS / TBVS)

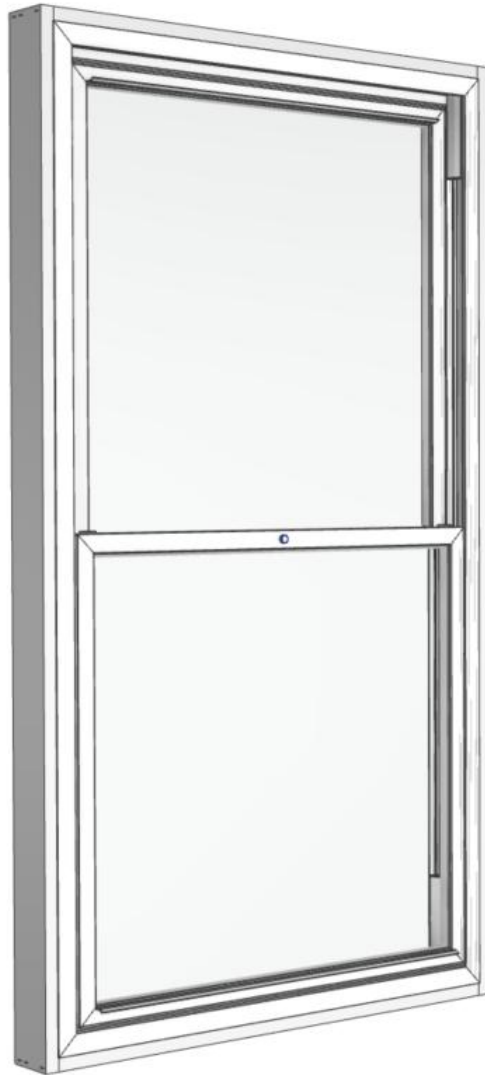

- 2.1 - BVS / TBVS Installation
- 2.2 - BVS Through Frame Fixing Hole Positions
- 2.3 - BVS Through Frame Fixing Hole Drilling
- 2.4 - TBVS Through Frame Fixing Hole Positions
- 2.5 - TBVS Through Frame Fixing Hole Drilling
- 2.6 - BVS Balance Adjustment
- 2.7 - TBVS Balance Adjustment
- 2.8 - BVS / TBVS Post Installation Check List



**IMPORTANT - TRANSPORT STRAP MUST NOT BE REMOVED UNTIL INSTALLATION IS FULLY COMPLETE
TRAVEL STOPS MUST NOT BE REMOVED UNDER ANY CIRCUMSTANCES**

**Note - It is critical that the window is fixed into the reveal as per the instructions on this sheet.
Failure to follow these instructions may result in poor operation, panels becoming detached or balance failure.**

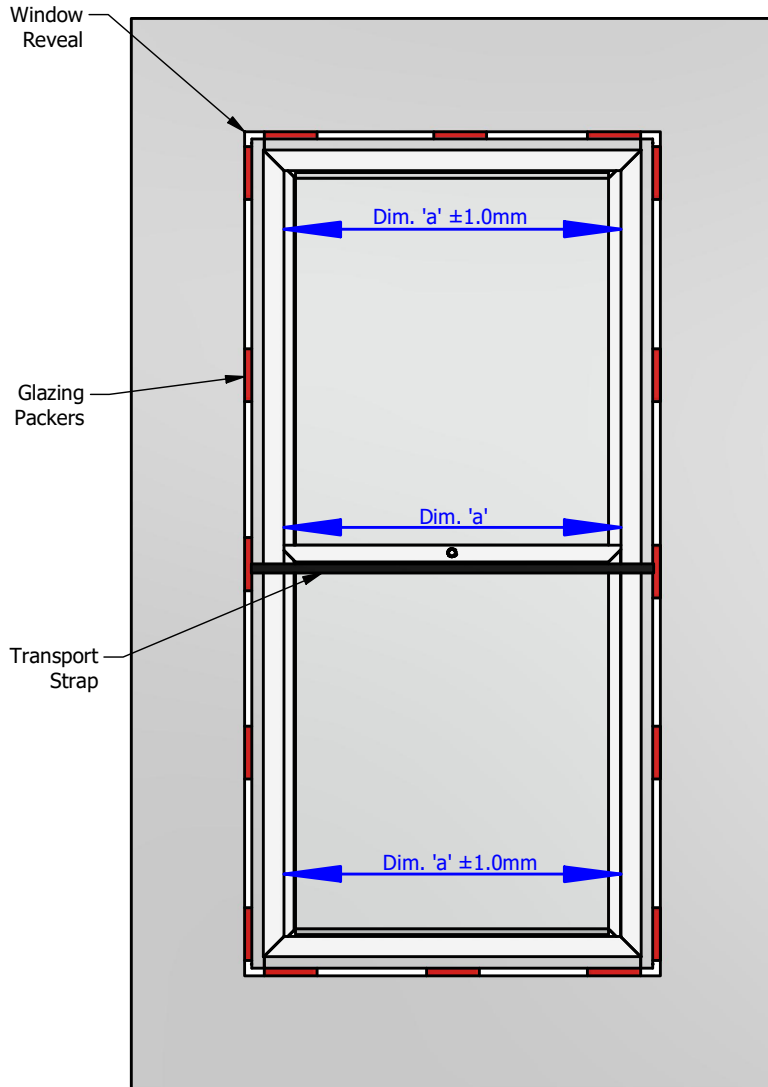

Face Fix

Face fix windows have fixing holes pre-drilled in the factory through the front face of the timber.

Step 1 - Follow the process for Through Timber / Through Frame fixing as described above ensuring all frame rails are within the acceptable tolerances of straightness.

Step 2 - Additional packers are also required at the rear between the timber subframe and what it is to be fixed to. The additional packers are required at all fixing positions and flatness across the front of the frame must not exceed $\pm 1.0\text{mm}/1\text{m}$ in any direction. Failure to pack the rear of the subframe may result in poor operation of the window.

Final Fix

Step 1 - Screw the frame to the reveal using appropriate screws for the building substrate with a minimum diameter of $\text{Ø}4.5\text{mm}$ and minimum thread engagement of 25mm.

Step 2 - Double check straightness of frame rails and diagonals.

Step 3 - Visually check that the frame jambs are parallel to the side of the panels.

Step 4 - When it is sure that the window has been fixed to the requirements of this sheet, remove the transport strap from the frame.

Through Timber Reveal Fix / Through Frame Reveal Fix

For through timber reveal fix windows, the fixing holes are pre-drilled in the factory through the face of the timber behind the outer frame.

For through frame reveal fix windows, it is required to drill fixing holes through the frame as detailed on the following pages of this manual.

Step 1 - Place window into reveal.

Step 2 - Pack the cill level using glazing packers at each screw hole position. If the window only has two fixing holes then an additional central packer should be used. Cill must be packed level to within $\pm 1.5\text{mm}$.

Step 3 - Pack the jambs using glazing packers at each screw hole location. For through frame fixing, additional glazing packers should be positioned approx. half way up the upper panel. Pack the jambs until they are visually parallel with the sides of the panel.

When the frame is packed parallel to the panel edges, measure the inside dimension of the frame at the top, middle and bottom. The measurement between both frame jambs must be equal for the entire length to within $\pm 1.0\text{mm}$ as shown by dim. 'a' in the diagram

Step 4 - Pack the frame head using glazing packers to ensure that it is not deformed when the head fixing screws are installed. Head must be packed to within $\pm 1.5\text{mm}$.

Step 5 - Measure across both diagonals of the frame. Acceptable difference for the two measurements is $((\text{frame height}/1000) \times 1.5)$. e.g. a 3000mm high frame will have an acceptable difference of 4.5mm and a 1000mm high frame will have an acceptable difference of 1.5mm.

If the difference between measurements exceeds this formula then packing of the head and cill should be adjusted until it is acceptable.



**IMPORTANT - TRANSPORT STRAP MUST NOT BE REMOVED UNTIL INSTALLATION IS FULLY COMPLETE
TRAVEL STOPS MUST NOT BE REMOVED UNDER ANY CIRCUMSTANCES**

Note - All through frame fixing holes must be drilled as per the instructions on page 2.3

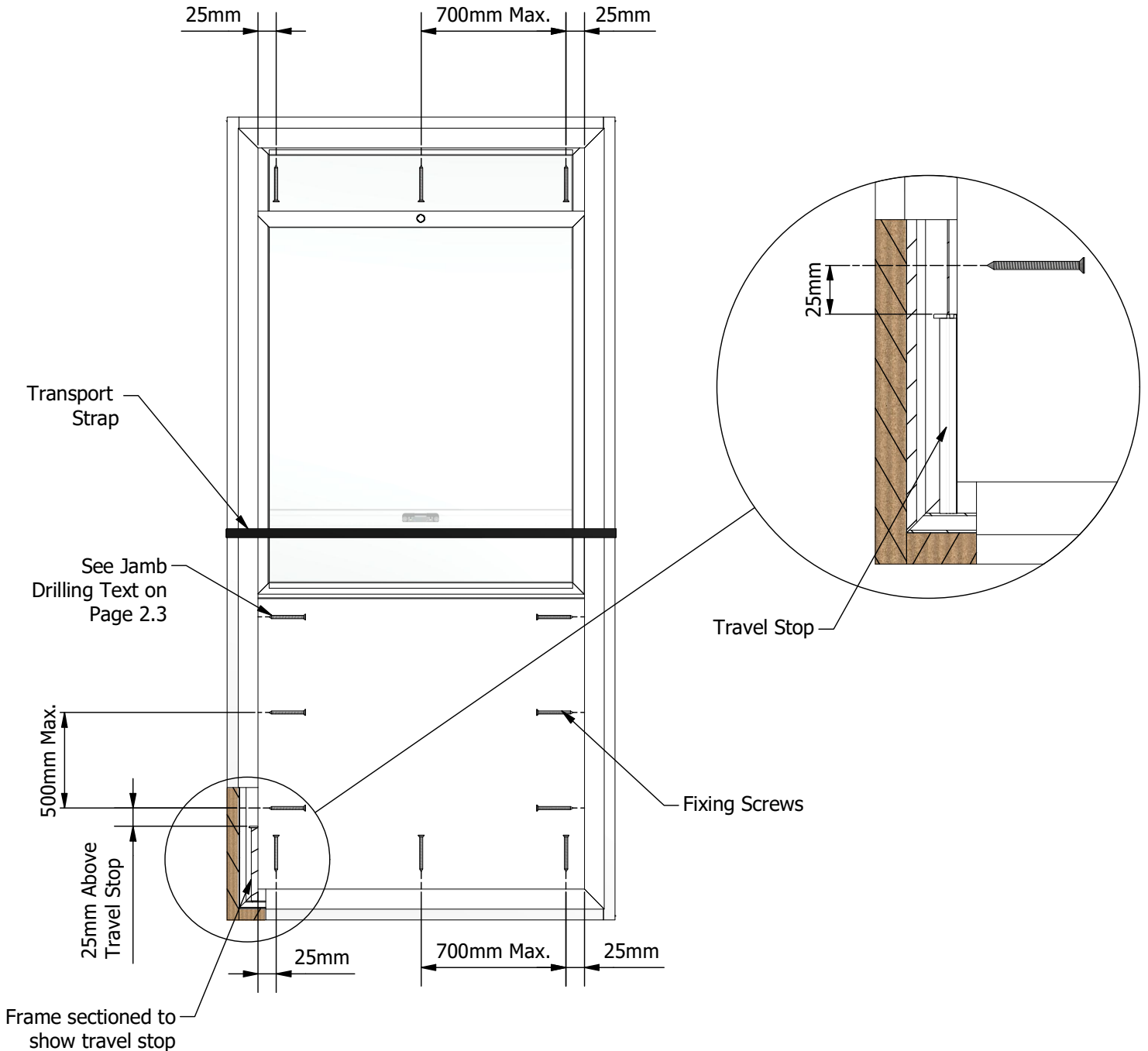

HDW-Z-02 Drill Block

All fixing holes must be drilled through the outer frame using the HDW-Z-02 drill block. This is to ensure that the holes are positioned correctly within the channels.

The fixing holes should only be drilled in the rear glazing channel.

When the drill block is in the correct orientation for the BVS window, the face shown in the RH image will be visible and the arrow will point towards the inside of the building.

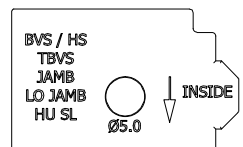



Jamb Drilling

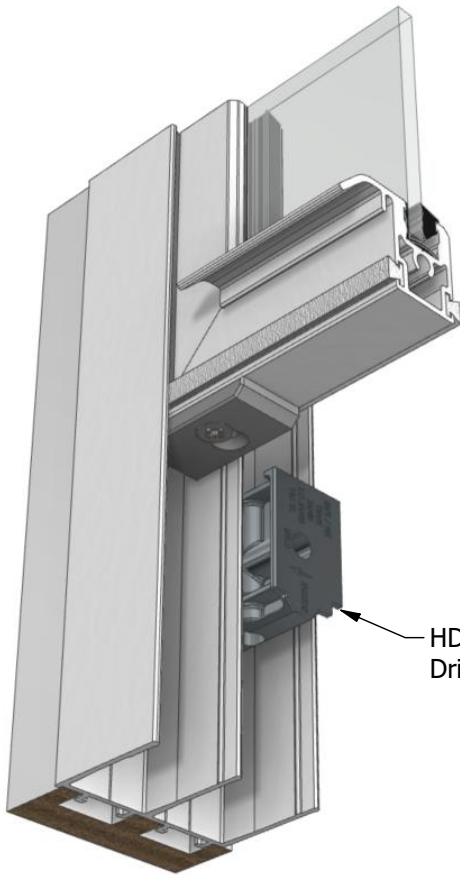

HDW-Z-02 Drill Block

Open the lower panel to the limit of its travel.
Place the HDW-Z-02 drill block into the rear channel in the orientation shown. Hold the drill block against the centre rib of the profile and position so that the first hole is 25mm above the lower travel stop.

Drill Ø5.00 through the aluminium frame and timber subframe (if fitted).

Place the drill block as far towards the upper panel as possible. Consideration should be given to accessibility to the fixing hole position during installation.

Drill Ø5.00 through the aluminium frame and timber subframe (if fitted).

Repeat the process for any required intermediate holes ensuring that the maximum spacing of 500mm is observed.

Countersink all holes Ø10.00 to ensure that the fixing screws will sit flush with the inside face of the frame.

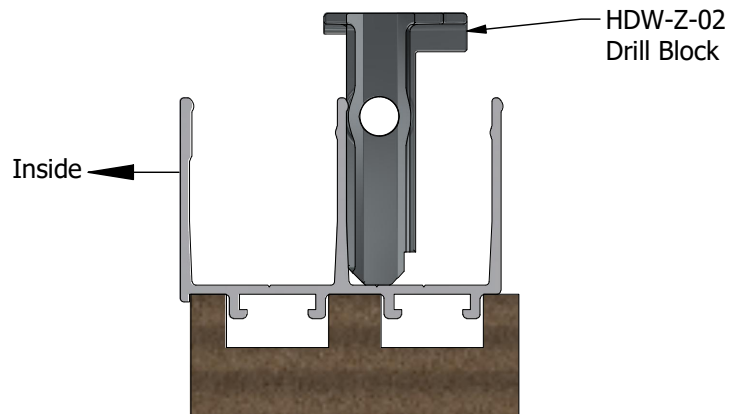

HDW-Z-02 Drill Block

Head / Cill Drilling

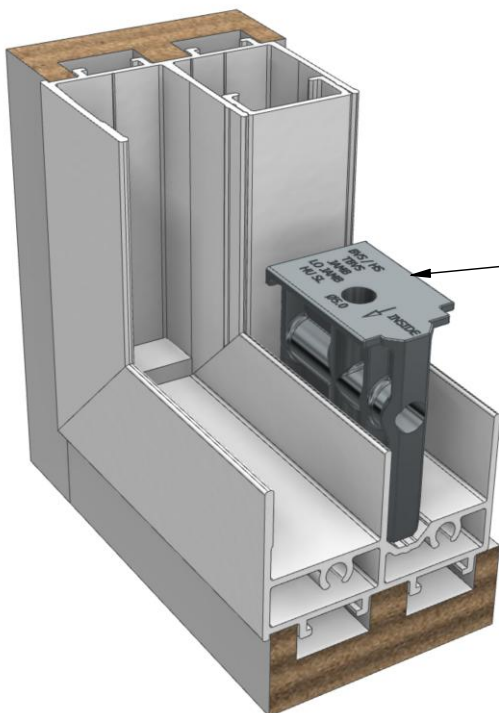

HDW-Z-02 Drill Block

Open the required panel to gain access to the head or cill. Place the HDW-Z-02 drill block into the rear channel in the orientation shown. The drill block will locate into the countersink feature of the frame profile.

Position the drill block 25mm from the frame corner.

Drill Ø5.00 through the aluminium frame and timber subframe (if fitted).

Repeat the process for the opposite corner and any required intermediate holes ensuring that the maximum spacing of 700mm is observed.

The head / cill holes do not require additional countersinking.

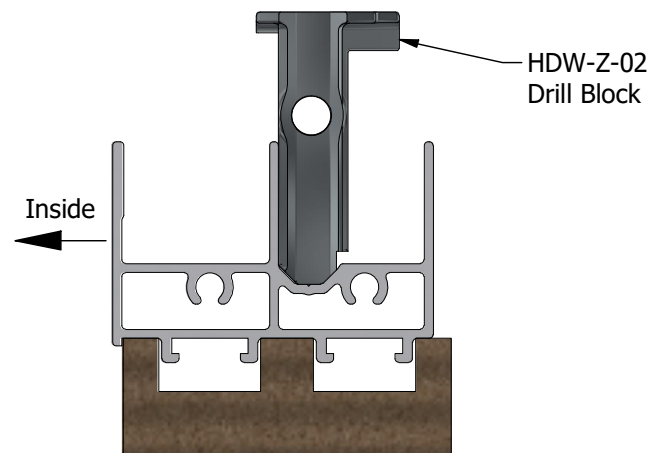

HDW-Z-02 Drill Block



**IMPORTANT - TRANSPORT STRAP MUST NOT BE REMOVED UNTIL INSTALLATION IS FULLY COMPLETE
TRAVEL STOPS MUST NOT BE REMOVED UNDER ANY CIRCUMSTANCES**

Note - All through frame fixing holes must be drilled as per the instructions on page 2.5

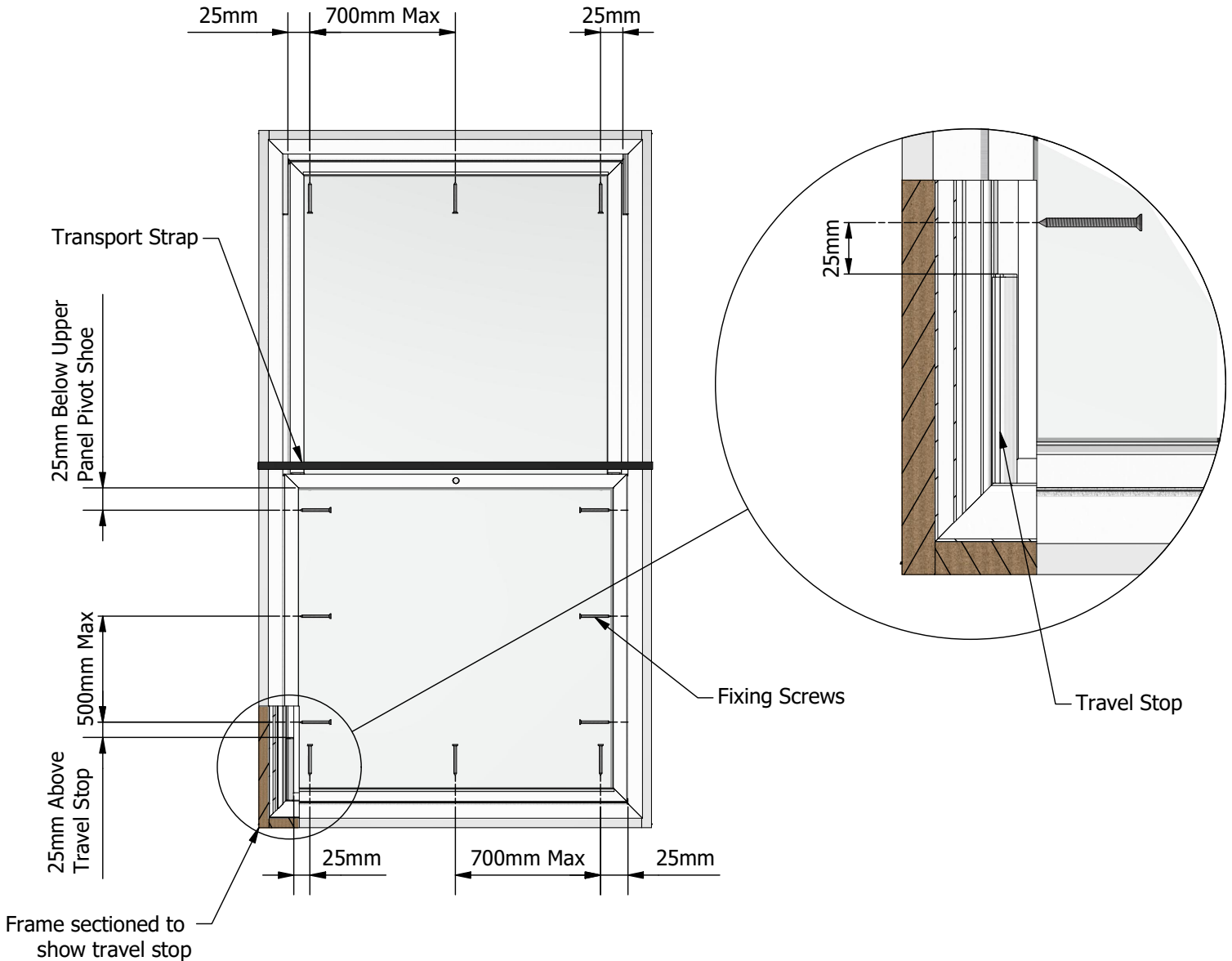

HDW-Z-02 Drill Block

All fixing holes must be drilled through the outer frame using the HDW-Z-02 drill block. This is to ensure that the holes are positioned correctly within the channels.

The fixing holes should only be drilled in the rear glazing channel. When the drill block is in the correct orientation for the TBVS window, the faces shown below will be visible and the arrow will point towards the inside of the building.

TBVS Jamb Orientation

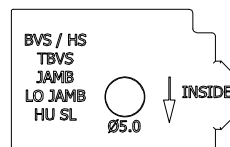

TBVS Head / Cill Orientation

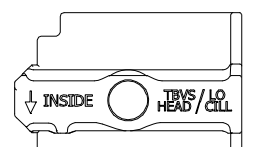



Jamb Drilling

Open the lower panel to the limit of its travel.
Place the HDW-Z-02 drill block into the rear channel in the orientation shown. Hold the drill block against the centre rib of the profile and position so that the first hole is 25mm above the lower travel stop.
Drill Ø5.00 through the aluminium frame and timber subframe (if fitted).

Close the lower panel and tilt it fully inwards. Place the drill block so that the hole is approx. 25mm below the upper panel pivot shoe.
Drill Ø5.00 through the aluminium and timber subframe (if fitted)

Tilt the lower panel back to its vertical position and open fully. Repeat the process for any required intermediate holes ensuring that the maximum spacing of 500mm is observed.

Countersink all holes Ø10.00 to ensure that the fixing screws will sit flush with the inside face of the frame. Any protrusion of the screw head above the frame will clash with the pivot shoe and prevent operation of the upper panel.

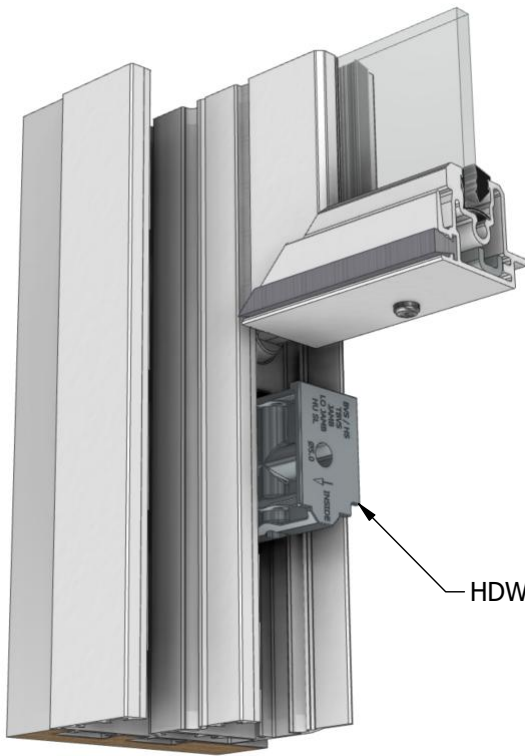

HDW-Z-02 Drill Block

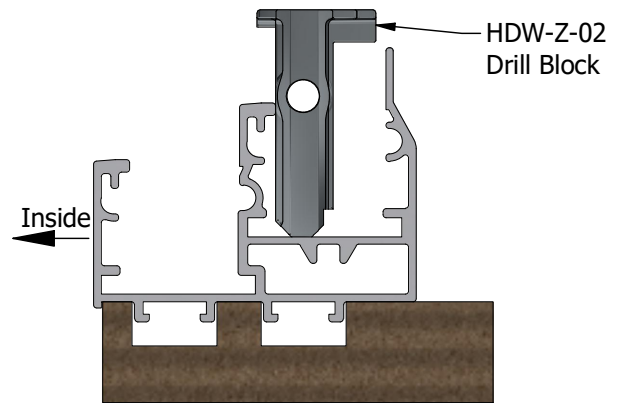

HDW-Z-02 Drill Block

Head / Cill Drilling

Open the required panel to gain access to the head or cill.
Place the HDW-Z-02 drill block into the rear channel in the orientation shown. The drill block will locate into the channel of the frame profile.
Position the drill block 25mm from the frame corner.
Drill Ø5.00 through the aluminium frame and timber subframe (if fitted).

Repeat the process for the opposite corner and any required intermediate holes ensuring that the maximum spacing of 700mm is observed.
Countersink all holes Ø10.00 to ensure the fixing screws are flush to the frame.

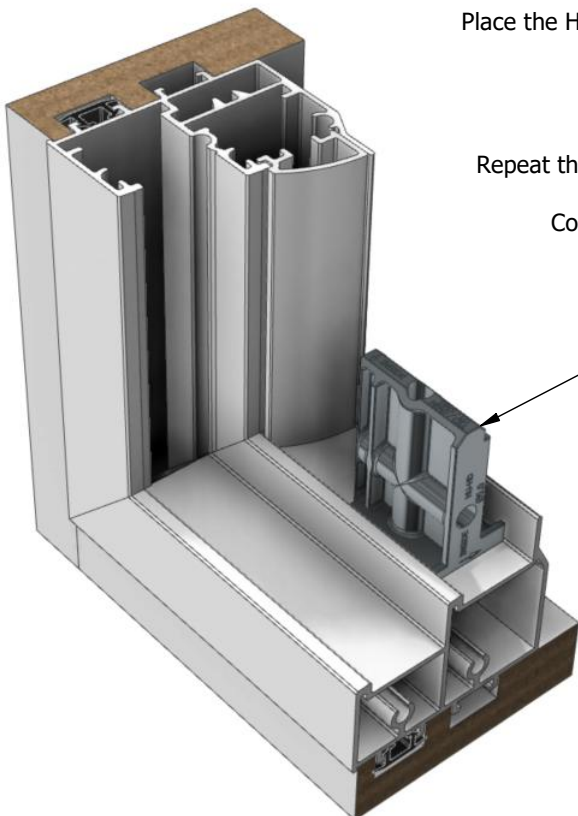

HDW-Z-02 Drill Block

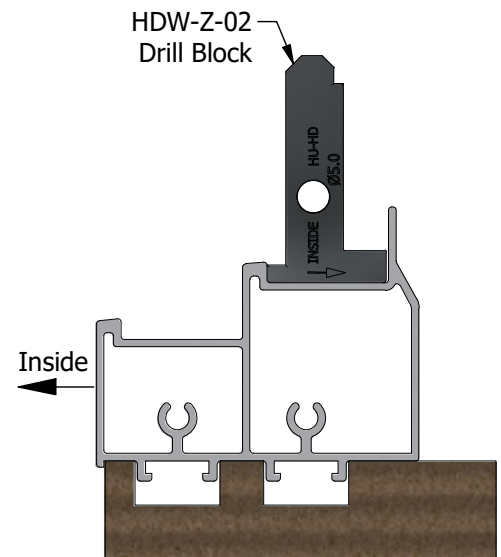

HDW-Z-02 Drill Block



NOTE: The panel must be fully and safely supported during the process so that it is unable to close whilst balance adjustment is being undertaken. A panel support tool is available from Granada Glazing (part No. HDW-Z-03).

Step 1 - (a) Remove the FIX-SCR-06 fixing screw from the balance bracket.

(b) Hook the balance tensioning tool over the lower pin of the balance rod with the tool in the orientation shown below.

(c) Pull the balance rod downwards to release the balance bracket from the panel.

(d) Remove the balance bracket from the balance rod by pulling it in the directions indicated by the red arrows below.

Important - Ensure that the balance tensioning tool is securely hooked on to the pins of the balance rod at all times as if the tool slips the tension of the balance is lost which could lead to balance failure.

Step 1a



Step 1b

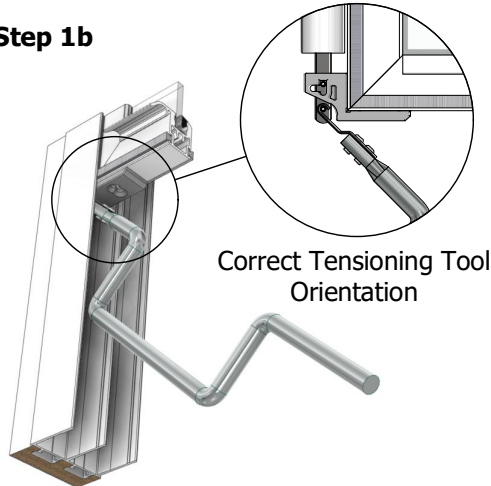

Step 1c

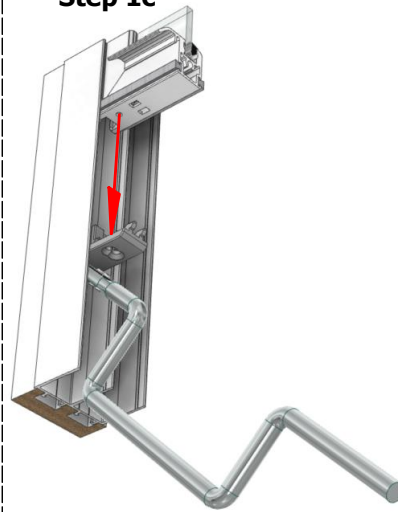

Step 1d

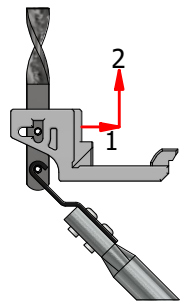

Step 2 - Pull the balance rod as far down as possible to minimise the angle of the tensioning tool. Care should be taken to ensure that the balance rod is not bent. Use the tensioning tool to turn the rod to adjust the balance tension as required. Direction of rotation for increasing / decreasing tension varies between different balance manufacturers



Step 3 - (a) Fit the balance bracket over the upper balance rod pin as shown below so that the pin sits in the vertical slot of the balance bracket.

(b) Rotate the bracket as far as it will move in the direction shown and retract the balance slowly until the bracket sits below the bottom panel rail. Align the two bracket hooks with the rectangular holes on the bottom of the panel

(c) Continue to allow the balance to retract, ensuring the bracket hooks locate into the rectangular holes. Fully retract the balance to rotate the bracket to its final position. Check that the bracket sits flush with the bottom of the panel.

(d) Remove the tensioning tool and refit the FIX-SCR-06 fixing screw through balance bracket.

Step 3a

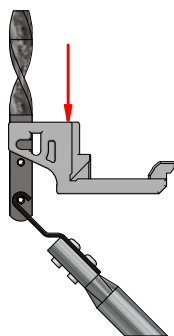

Step 3b

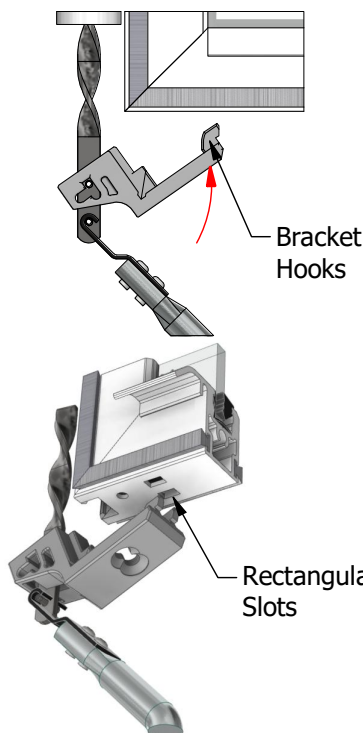

Step 3c

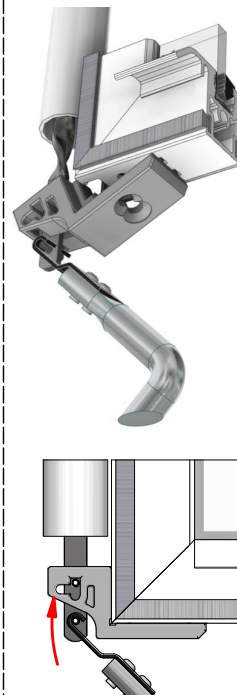

Step 3d

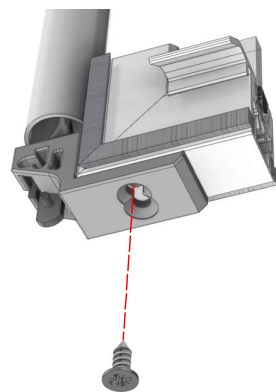



Step 1 - Tilt in the panel until it is supported by the tilt restrictors. Open the red tilt restrictor retaining tabs located on both sides of the panel and slide the tilt restrictors from the panel. Lower the panel to a horizontal position, ensuring it is supported, to gain access to the balance rod pins.

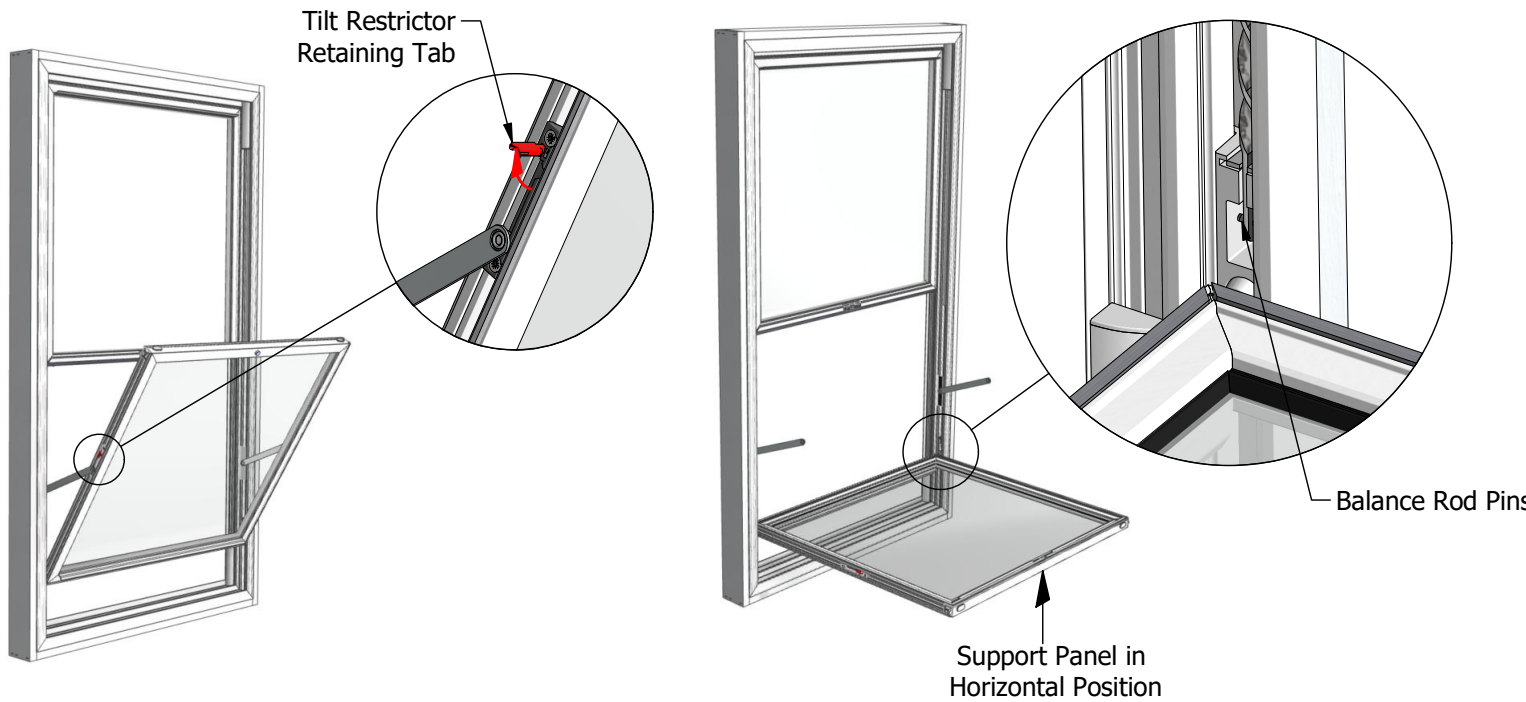

Step 2 - Hook the balance tensioning tool over the lower pin of the balance rod. Pull downwards and away from the frame to release the balance rod from the pivot shoe

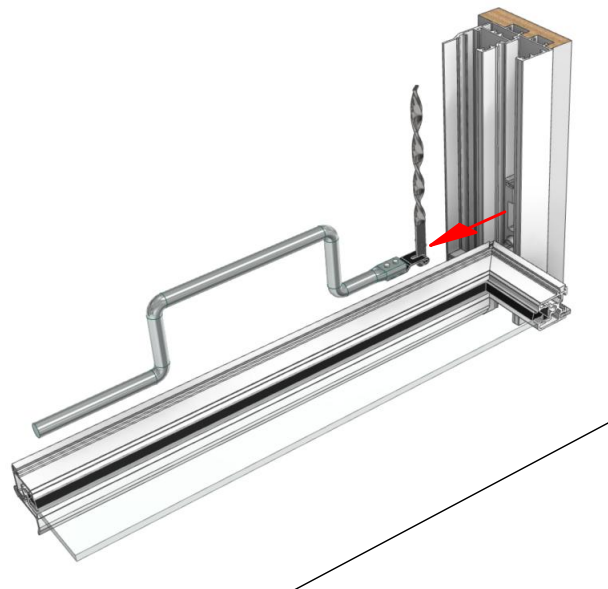

Step 3 - Use the balance tensioning tool to turn the rod to adjust the balance tension as required. Direction of rotation for increasing / decreasing tension varies between different balance manufacturers. Re-assembly is a reversal of the previous steps. Hook the upper balance rod pin back into the pivot shoe ensuring it is securely located behind the step and can't become detached. Tilt the panel up and re-connect the tilt restrictors, ensuring that the red tilt restrictor retaining tabs are securely clipped in position to prevent the restrictors becoming detached.

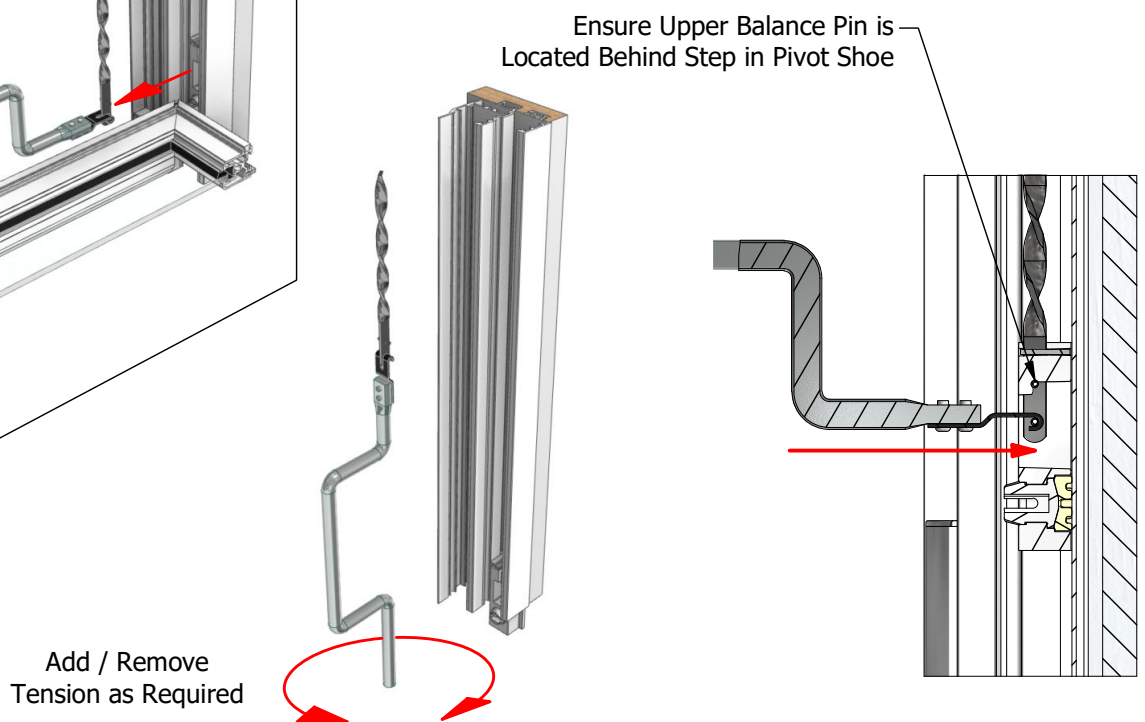



General

✓

x

Panels visually square in outer frame		
Visual condition of paint and glass		

Operation of lower panel

Panel opens all of the way to travel stop smoothly		
Panel does not drop when fully open		
Panel does not lift when fully closed		
Panel does not lift or drop in middle position		
Tilt latches release and panel tilts in to restrictors (TBVS only)		
Tilt latches auto engage when panel is in closed position (TBVS only)		

Operation of upper panel

Panel opens all of the way to travel stop smoothly		
Panel does not drop when fully closed		
Panel does not lift when fully open		
Panel does not lift or drop in middle position		
Tilt latches release and panel tilts in to restrictors (TBVS only)		
Tilt latches auto engage when panel is in closed position (TBVS only)		

Release Latch

Latch automatically engages and secures panels when both panels are shut		
Push button releases latch with light to moderate pressure		

Comments



Section 3

Horizontal Sliding Windows (HS)



- 3.1 - HS Installation
- 3.2 - HS Through Frame Fixing Hole Positions
- 3.3 - HS Through Frame Fixing Hole Drilling
- 3.4 - HS Panel Installation
- 3.5 - HS Panel Alignment
- 3.6 - HS Restrictor/Anti Lift Block Installation
- 3.7 - HS Post Installation Check List



Note - It is critical that the window is fixed into the reveal as per the instructions on this sheet.

Failure to pack the cill correctly and square the frame across the diagonals will result in poor operation and substandard window performance.

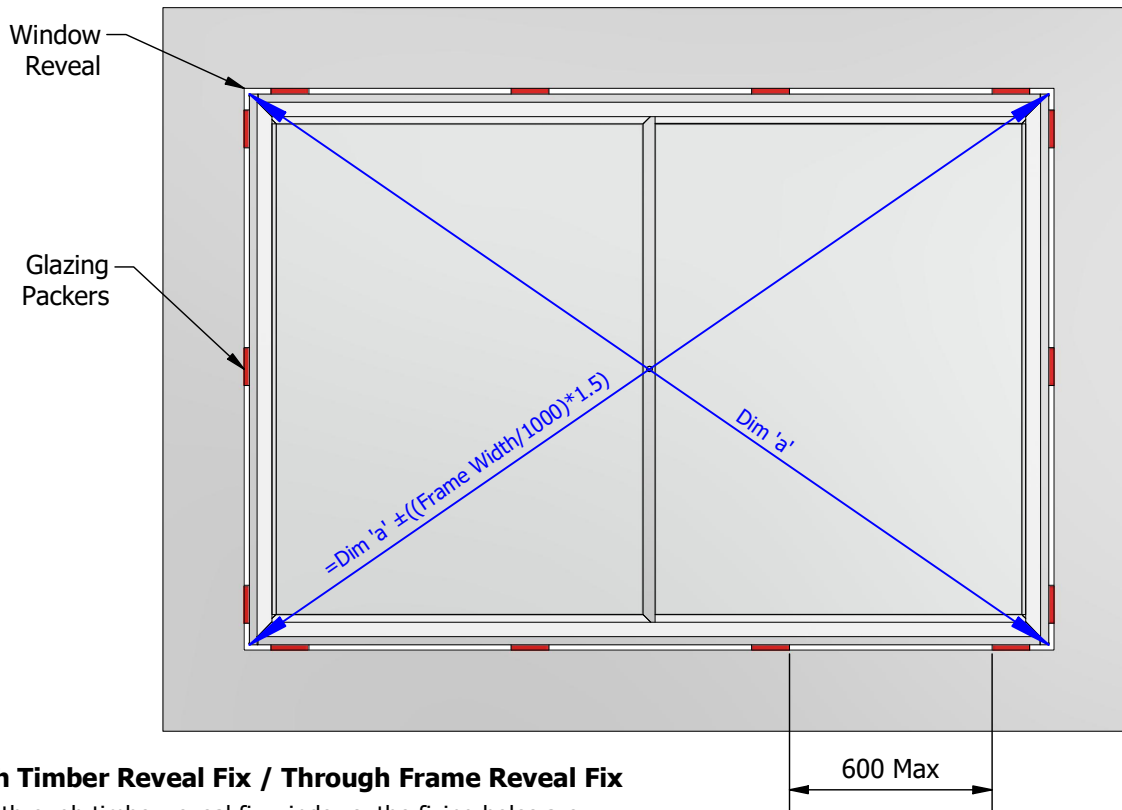

Through Timber Reveal Fix / Through Frame Reveal Fix

For through timber reveal fix windows, the fixing holes are pre-drilled in the factory through the face of the timber behind the outer frame.

For through frame reveal fix windows, it is required to drill fixing holes through the frame as detailed on the following pages of this manual.

Step 1 - Place window in to reveal.

Step 2 - Pack the cill level using glazing packers at each screw hole position. Intermediate packers must be fitted with a maximum spacing of 600mm.

Cill must be packed level to within $\pm 1\text{mm/m}$.

Failure to correctly pack the cill level will result in poor window performance.

Step 3 - Pack the jambs using glazing packers at each screw hole location.

Jambs must be packed level to within $\pm 1.0\text{mm}$ across their entire length.

Step 4 - Pack the frame head using glazing packers to ensure that it is not deformed when the head fixing screws are installed.

Head must be packed to within $\pm 1.5\text{mm}$.

Step 5 - Measure across both diagonals of the frame. Acceptable difference for the two measurements is $((\text{frame width}/1000)*1.5)$. e.g. a 3000mm wide frame will have an acceptable difference of 4.5mm and a 1000mm wide frame will have an acceptable difference of 1.5mm.

If the difference between measurements exceeds this formula then packing of the head and cill should be adjusted until it is acceptable.

Face Fix

Face fix windows have fixing holes pre-drilled in the factory through the front face of the timber.

Step 1 - Follow the process for Through Timber / Through Frame fixing as described above ensuring all frame rails are within the acceptable tolerances of straightness.

Step 2 - Additional packers are also required at the rear between the timber subframe and what it is to be fixed to. The additional packers are required at all fixing positions and flatness across the front of the frame must not exceed $\pm 1.0\text{mm}/1\text{m}$ in any direction.

Failure to pack the rear of the subframe may result in poor operation of the window.

Final Fix

Step 1 - Screw the frame to the reveal using appropriate screws for the building substrate with a minimum diameter of $\varnothing 4.5\text{mm}$ and minimum thread engagement of 25mm.

Step 2 - Double check straightness of frame rails and diagonals and re-pack if necessary.

Step 3 - Double check flatness of cill and re-pack level if necessary.

Step 4 - Install panels as covered on page 3.4 and double check panel alignment as shown on page 3.5.

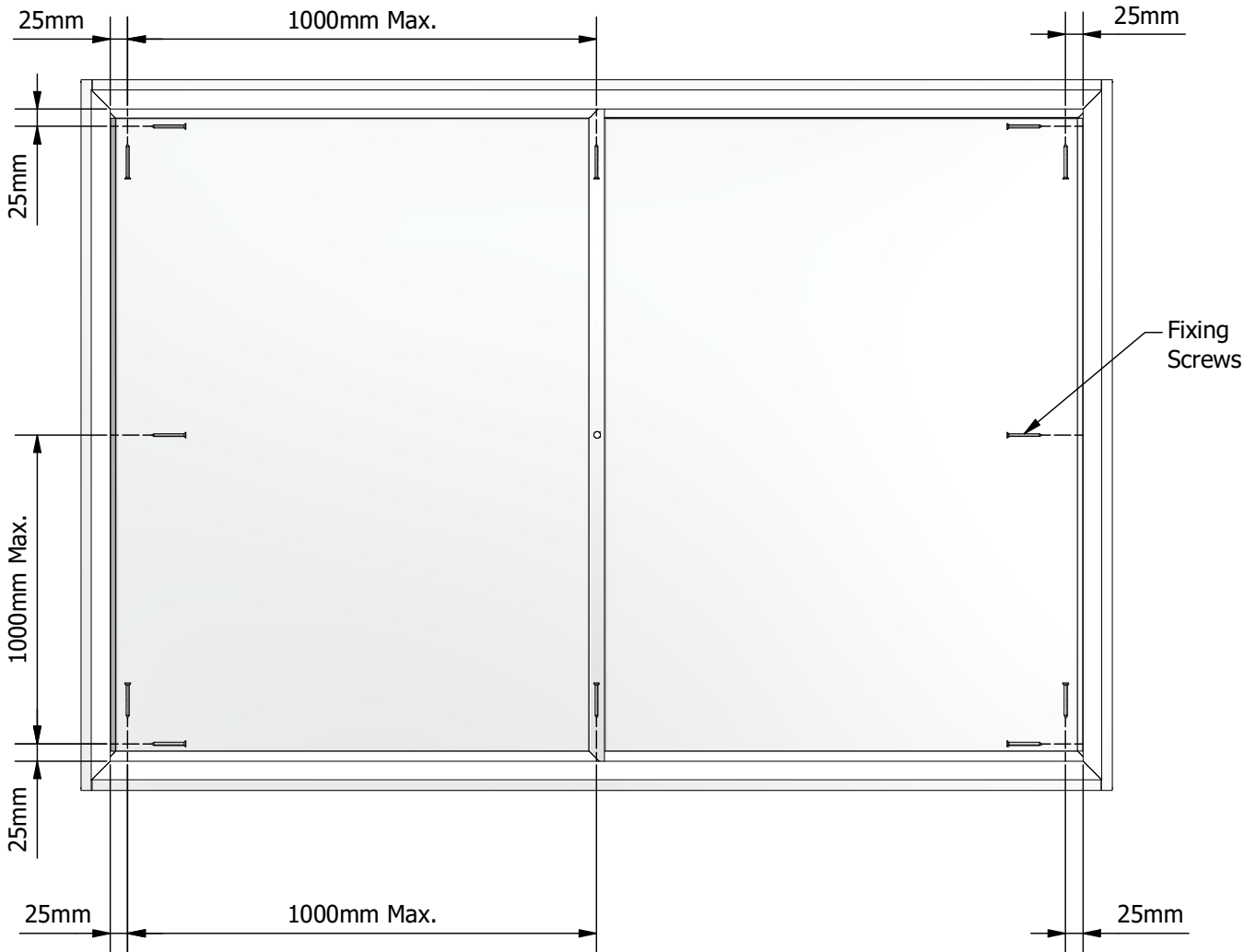

HDW-Z-02 Drill Block

All fixing holes must be drilled through the outer frame using the HDW-Z-02 drill block. This is to ensure that the holes are positioned correctly within the channels.

The fixing holes should only be drilled in the rear glazing channel.

When the drill block is in the correct orientation for the HS window, the face shown below will be visible and the arrow will point towards the inside of the building.

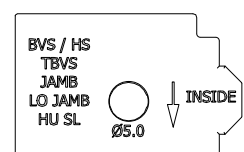



Important - HS outer frames should always be installed with the panels removed and all debris from the installation process fully removed before fitting the panels

Head Drilling

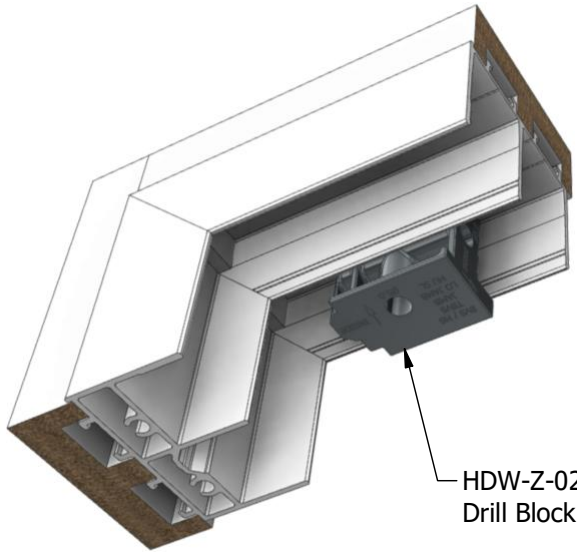

Place the HDW-Z-02 drill block into the rear channel in the orientation shown. Hold the drill block against the centre rib of the profile.
Position the drill block 25mm from the frame corner. Drill Ø5.00 through the aluminium frame and timber subframe (if fitted).

Repeat the process for the opposite corner and any required intermediate holes ensuring that the maximum spacing of 1000mm is observed.
Countersink the holes Ø10mm to ensure that the screw heads are flush with the face of the frame.

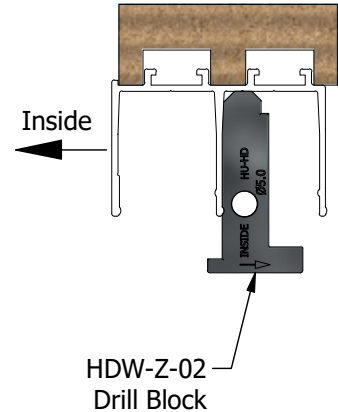

HDW-Z-02 Drill Block

Jamb Drilling

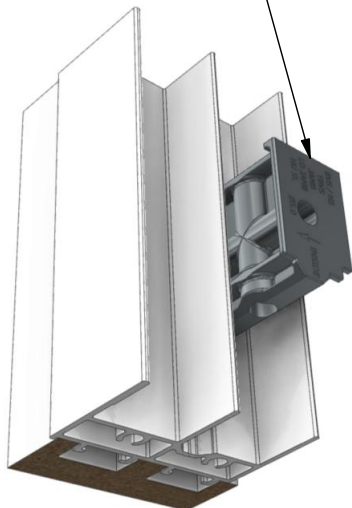

Place the HDW-Z-02 drill block into the rear channel in the orientation shown. The drill block will locate into the countersink feature of the frame profile.
Position so that the first hole is 25mm above the inside edge of the frame.
Drill Ø5.00 through the aluminium frame and timber subframe (if fitted).

Place the drill block at the top of the jamb with the hole position 25mm below the inside edge of the frame.
Drill Ø5.00 through the aluminium frame and timber subframe (if fitted).

Repeat the process for any required intermediate holes ensuring that the maximum spacing of 1000mm is observed.

The jamb fixing holes do not require additional countersinking.

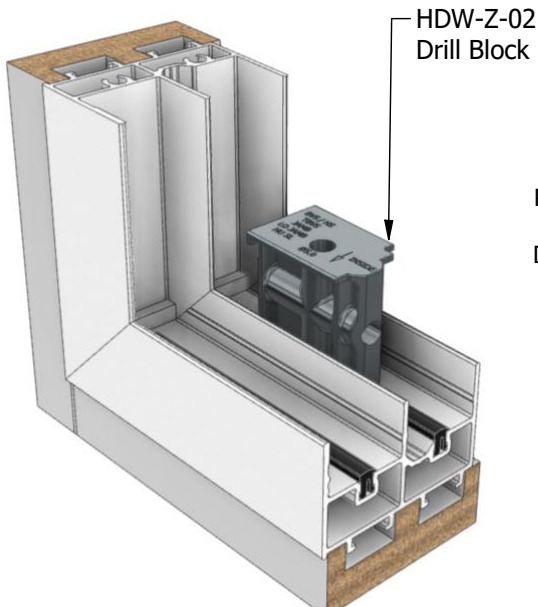
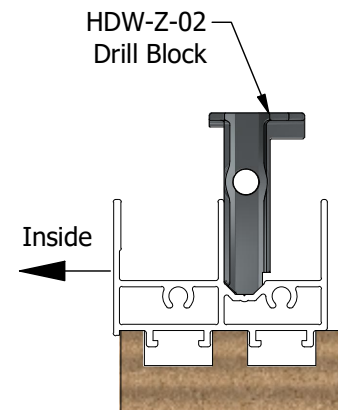

Cill Drilling

Place the HDW-Z-02 drill block into the rear channel in the orientation shown. The drill block will locate into the countersink feature of the frame profile.
Position so that the first hole is 25mm from the inside edge of the frame.
Drill Ø5.00 through the aluminium frame and timber subframe (if fitted).

Repeat the process for the opposite corner and for any required intermediate holes ensuring that the maximum spacing of 1000mm is observed.

The cill fixing holes do not require additional countersinking.

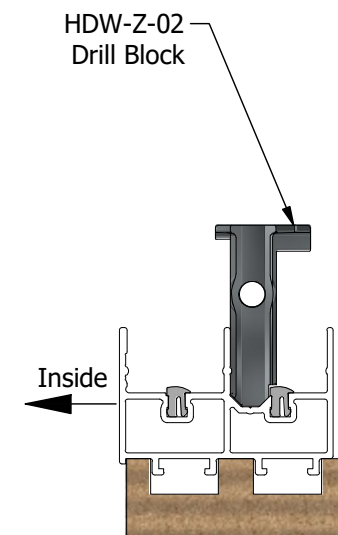

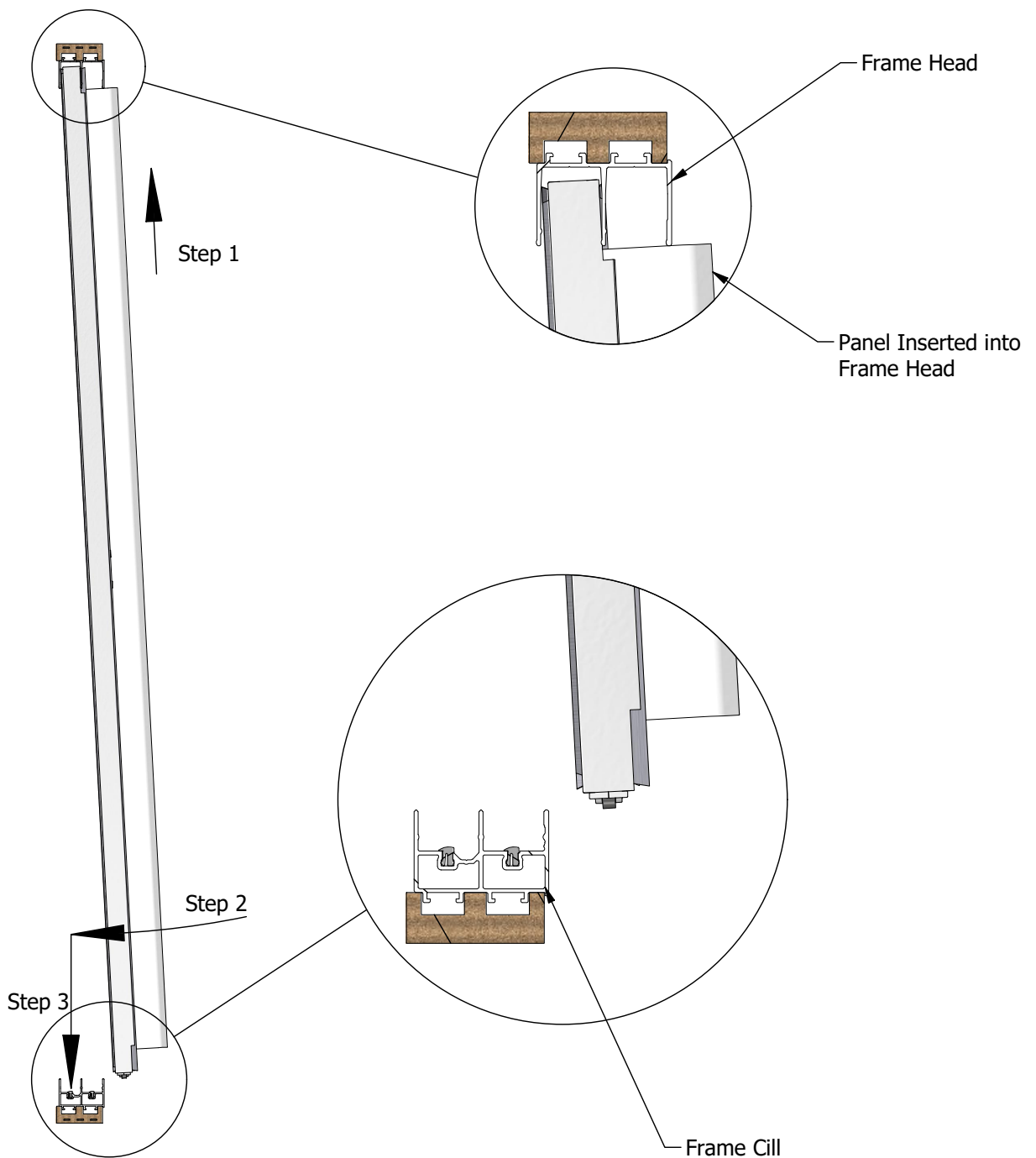

Always install all rear panels before installing the front panels.
Granada Glazing always recommend the use of glass suckers when fitting or removing panels.

Step 1 - Angle the panel so that the top rail can be slid into the appropriate track in the frame head.

Step 2 - With the panel top rail as far into the head track as possible, rotate the bottom of the panel inwards until it is aligned with the appropriate channel in the frame cill profile. Extra care should be taken to ensure the panel remains as far upwards as possible during this step to prevent the panel rollers from clashing with the frame and becoming damaged.

Step 3 - With the panel aligned with the channel in the cill profile, lower the panel until the rollers are supporting the weight.

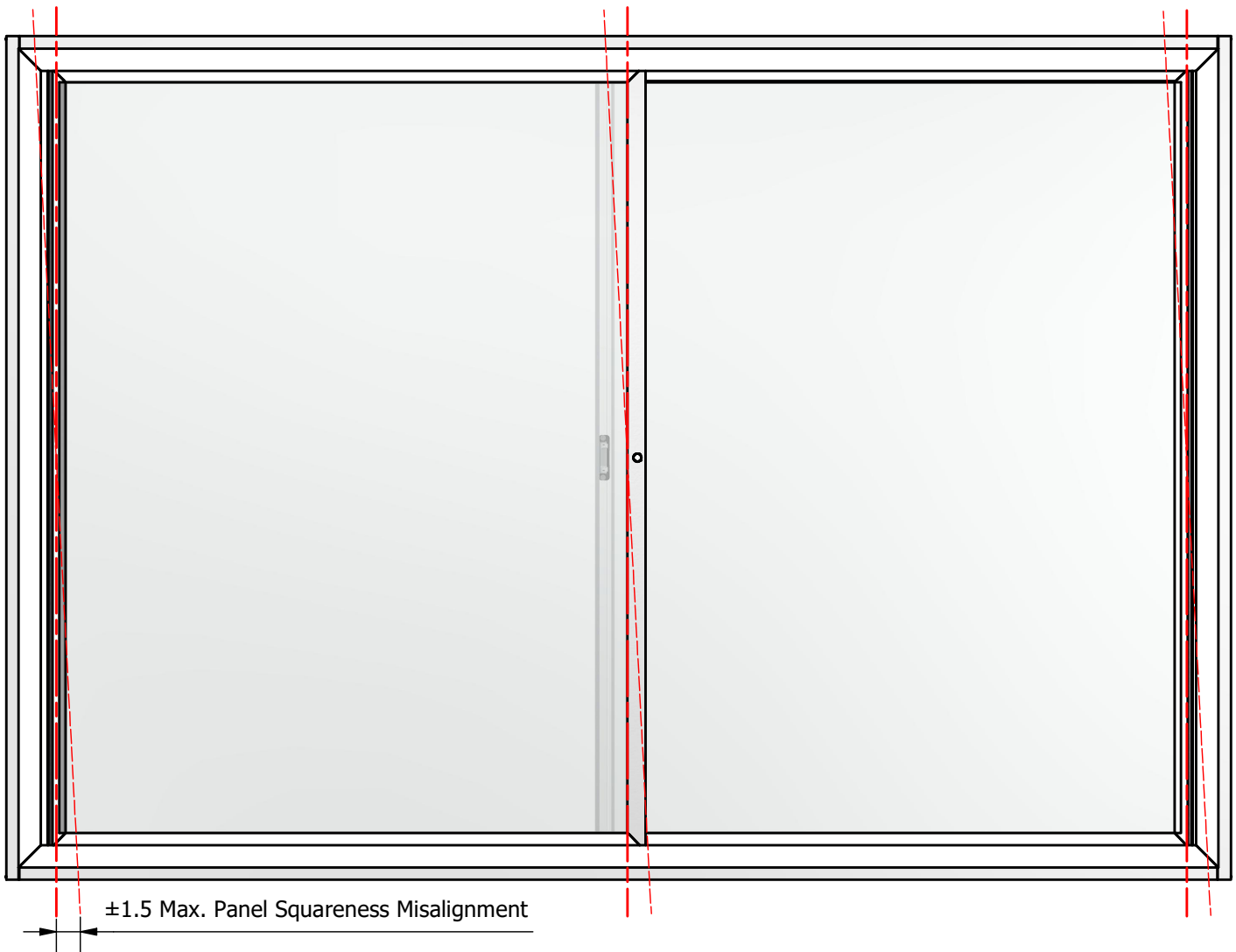

It is important that after panel installation, the alignment of the panels relative to the outer frame and their adjacent panels is checked. If the panels are misaligned then the window will suffer from poor sealing and the lock will be prevented from engaging.

Step 1 - Open the end panel so that there is approx. 5mm gap between the inside of the outer frame jamb and the edge of the panel. Visually check that the edge of the panel is parallel to the edge of the frame jamb to within ± 1.5 mm.

Step 2 - Repeat for the opposite end panel.

Step 3 - Close the end panels and open the next panel so that there is approx. 5mm gap between the panel rails. On reverse interlock panels this gap may be visible through the front panel glass. Visually check that the panel edges are parallel to each other to within ± 1.5 mm

Step 4 - Repeat the process for all remaining panels.

Misalignment of the panels is almost always caused by poor cill packing or the difference in measurements across the frame diagonals being too large.

Check the frame diagonals and re-pack the jambs if necessary to ensure panel sides align with frame jambs.
Check the flatness of the cill and re-pack if necessary.

The cill can be packed locally to the panel rollers to straighten individual panels but this should only be done if repacking the frame still does not bring the panels square.

To pack the cill to square a specific panel, place or remove packers as necessary 100mm in from the panel corners.



The COM-A0-45-KIT Restrictor / Anti Lift Block Kit is used to prevent the panels from being lifted out of the frame and also to restrict the amount of panel opening. It is recommended to restrict the window opening to 100mm where there is a chance that vulnerable people, such as small children, could potentially fall from the window.

Note - Instructions are for panel 1 only but the procedure is the same for all panels.

STEP 1 - With panel 1 fully closed, measure from the face of the interlock as shown and mark the required restricted dim with a pencil line.

Measure 50mm back towards panel 1 from the first pencil line and mark a second line. This second line will align with the edge of the restrictor block as shown.

Place a restrictor block from COM-A0-45-KIT so that the edge is aligned with the pencil mark.

Push the restrictor block fully into the head channel.

Using a Ø2.5mm drill, spot through the hole in the restrictor block and drill through the aluminium profile.

Screw the restrictor block into position using a screw supplied in the COM-A0-45-KIT.

STEP 2 - Open panel 1 fully and repeat the operation detailed in step 1 at all additional head positions shown in the image below.

STEP 3 - Close panel 1 fully and working at the track, measure from the face of the interlock as shown and mark the required restricted dim with a pencil line.

Place a restrictor block from COM-A0-45-KIT so that the edge is aligned with the pencil mark.

Push the restrictor block fully into the track channel and repeat the drill (through one wall of the aluminium profile) and screw process from step 1.

NOTE: Double check that the panel is successfully restricted and can't be lifted from the frame at any position.

STEP 1

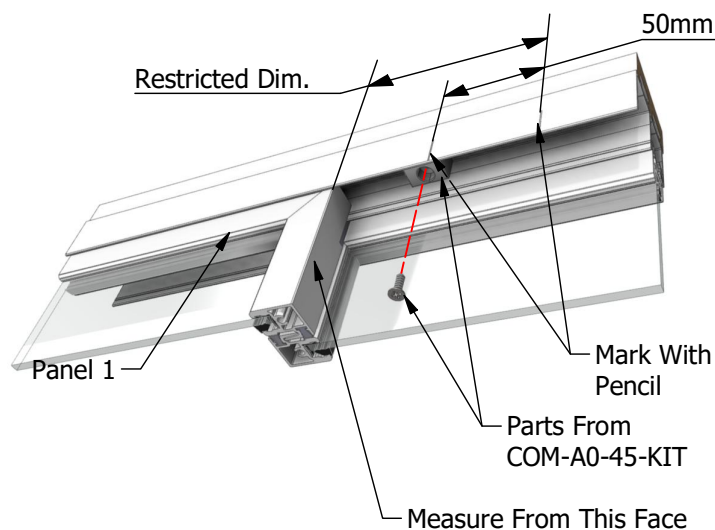

STEP 2

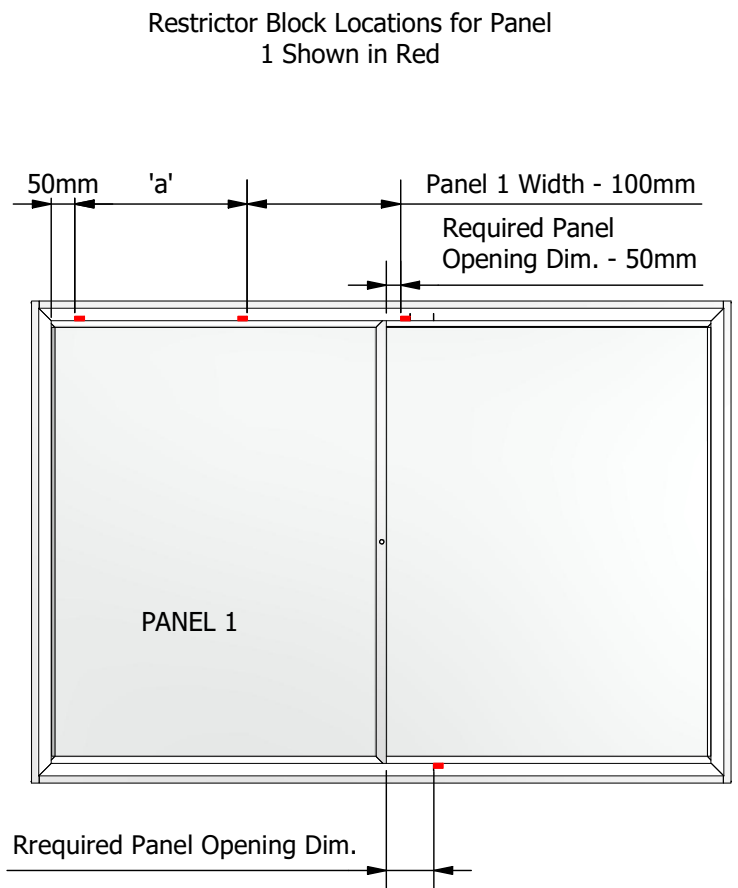

STEP 3

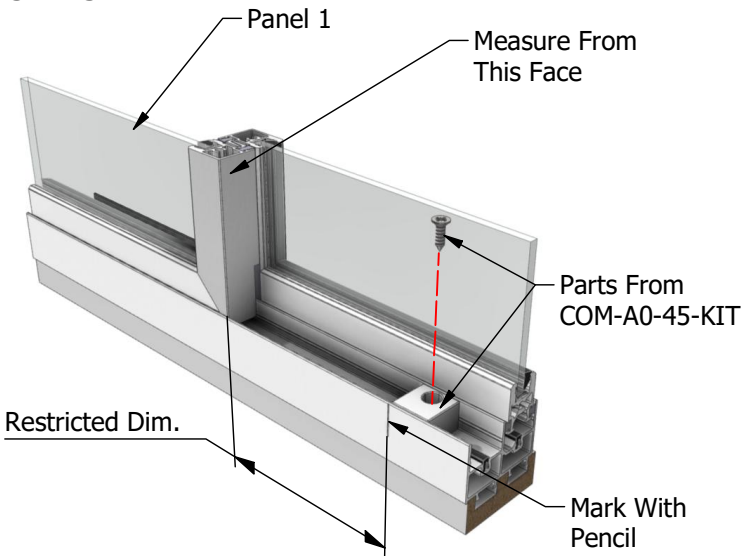

If dim. 'a' > (panel 1 width - 100mm), an additional restrictor block will be required above the panel to prevent lifting when the panel is closed.



General

✓

x

Panels visually square in outer frame		
Panels visually square to adjacent panels		
Visual condition of paint and glass		

Operation of panels

All panels move through their limits of travel smoothly		
---	--	--

Release Latch

All latches automatically engage and secures panels when panels are shut		
All push buttons release latches with light to moderate pressure		

Comments



Section 4

Hinged Units (HU-HD / HU-SL)



- 4.1 - HU-HD Installation
- 4.2 - HU-HD Through Frame Fixing Hole Positions
- 4.3 - HU-HD Through Frame Fixing Hole Drilling
- 4.4 - HU-SL Installation
- 4.5 - HU-SL Through Frame Fixing Hole Positions
- 4.6 - HU-SL Through Frame Fixing Hole Drilling
- 4.7 - HU-HD / HU-SL Post Installation Check List



Important - To prevent serious injury, do not open the panel during installation unless it is securely supported.

Note - It is critical that the window is fixed into the reveal as per the instructions on this sheet.

Failure to pack the frame square to the panel will result in poor operation and substandard window performance.

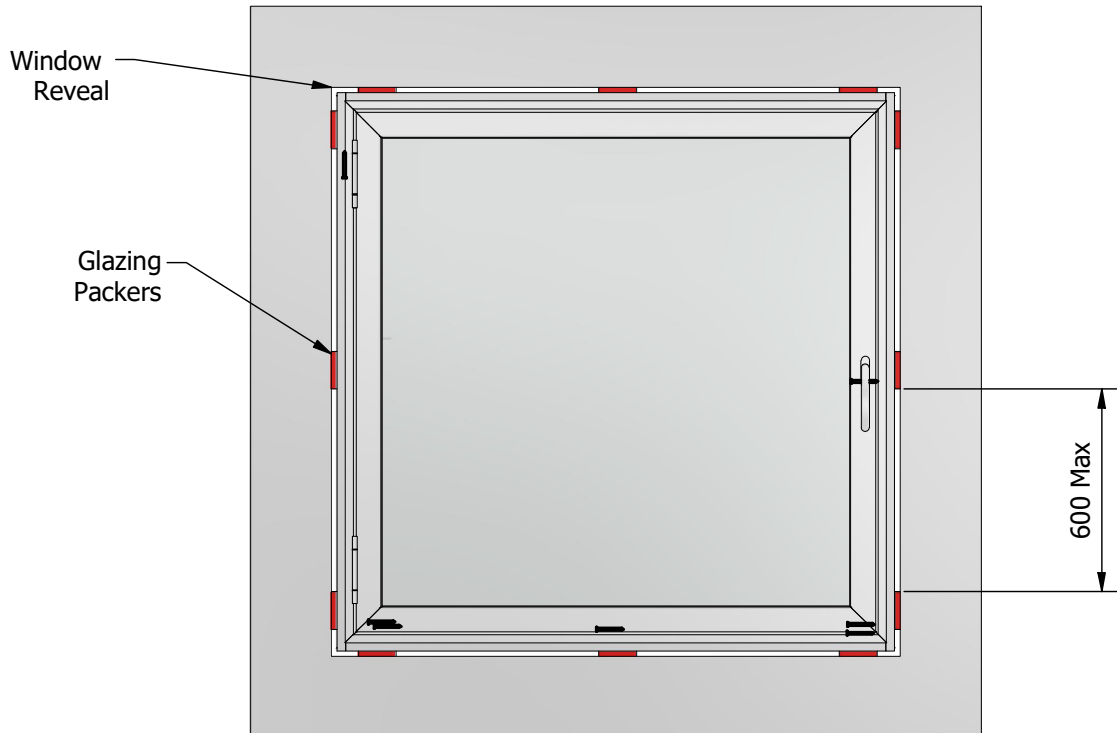

Through Timber Reveal Fix / Through Frame Reveal Fix

For through timber reveal fix windows, the fixing holes are pre-drilled in the factory through the face of the timber behind the outer frame.

For through frame reveal fix windows, it is required to drill fixing holes through the frame as detailed on the following pages of this manual.

HU-HD panels are squared in the factory so it is critical that the outer frame is packed square to the panel as adjusting the panel squareness will require de-glazing and toe and heeling the glass.

Step 1 - Place window in to reveal.

Step 2 - Use glazing packers to pack both sides of each corner tightly to prevent unwanted window movement during the squaring process.

Step 3 - Add or remove packers one at a time, until the panel has approx. the same gap to the frame at all four corners.

Step 4 - Add additional intermediate packers along all four sides ensuring that all four frame rails are straight to within $\pm 1\text{mm}$.

Face Fix

Face fix windows have fixing holes pre-drilled in the factory through the front face of the timber.

Step 1 - Follow the process for Through Timber / Through Frame fixing as described above ensuring all frame rails are within the acceptable tolerances of straightness.

Step 2 - Open the panel 90° ensuring that it is securely supported for the remainder of the installation process.

Step 3 - Additional packers are also required at the rear between the timber subframe and what it is to be fixed to. The additional packers are required at all fixing positions and flatness across the front of the frame must be within $\pm 1.0\text{mm}/1\text{m}$ in all directions.

Failure to pack the rear of the subframe may result in poor operation of the window.

Final Fix

Step 1 - Carefully open the panel 90° and securely support it ensuring that it is not applying load to the outer frame.

Step 2 - Screw the corners of the frame to the reveal using appropriate screws for the building substrate with a minimum diameter of $\text{Ø}4.5\text{mm}$ and minimum thread engagement of 25mm.

Step 3 - Close the panel and double check that the outer frame to panel gap is still equal around the perimeter. Double check that the run up block does not have to lift the panel more than 1mm. Double check that no hardware, such as keeps, catch during opening or closing. Loosen screws and re-pack the frame corners if necessary until these conditions are met.

Step 4 - Once panel alignment is acceptable, open and support the panel and screw the frame to the building substrate through the remaining intermediate holes.

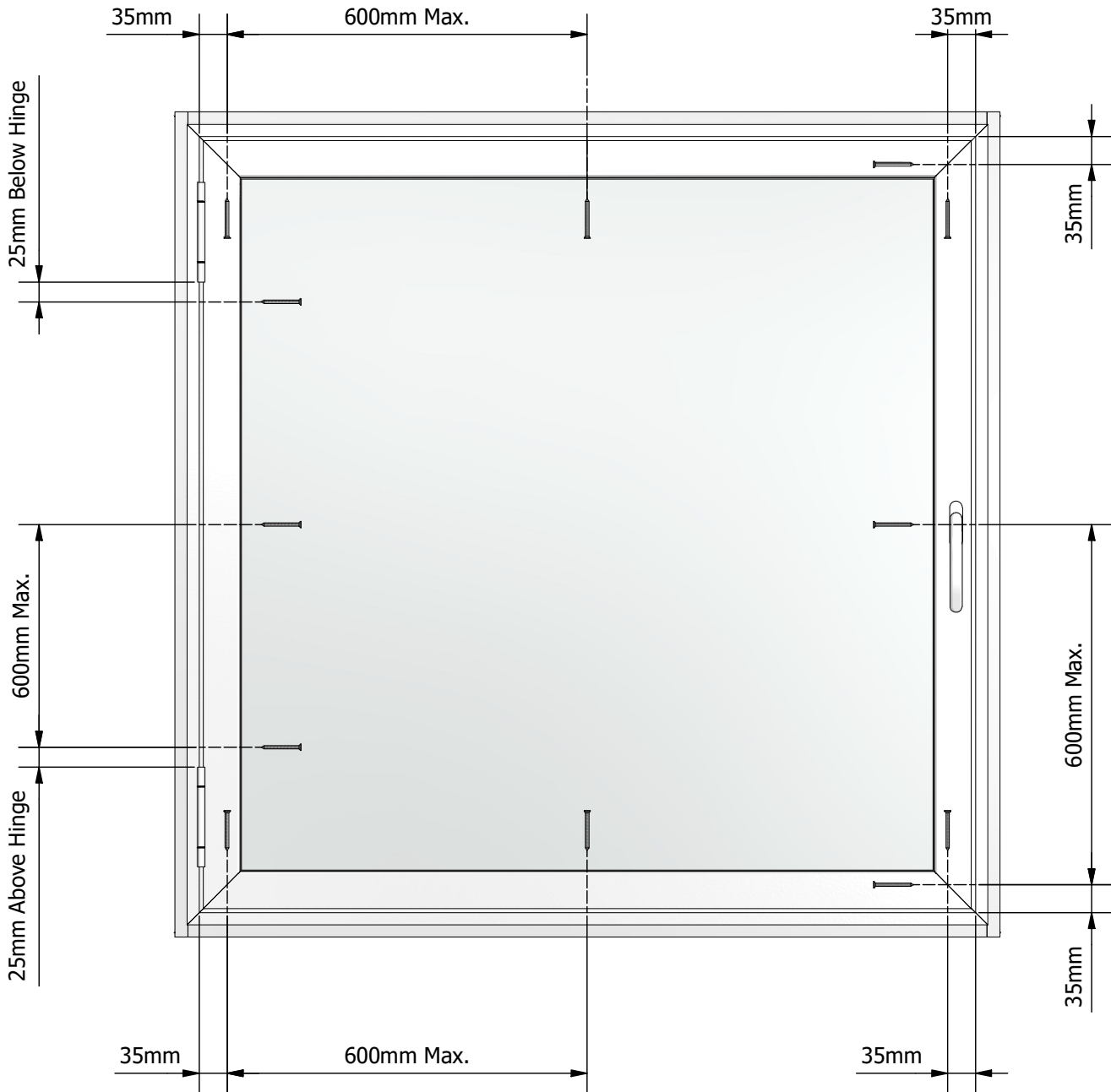

HDW-Z-02 Drill Block

All fixing holes must be drilled through the outer frame using the HDW-Z-02 drill block. This is to ensure that the holes are positioned correctly within the channels. When the drill block is in the correct orientation for the HU-HD window, the face shown in the right hand image will be visible and the arrow will point towards the inside of the building.

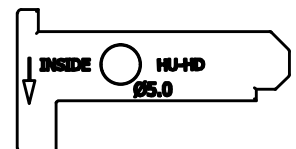



Frame Drilling - Hinge Side

Place the HDW-Z-02 drill block into the screw channel in the orientation shown. The drill block will locate into the countersink feature of the frame profile.

Position the drill block 25mm above the lower hinge.
Drill Ø5.00 through the aluminium frame and timber subframe (if fitted).

Repeat the process for upper hinge with the drill block positioned 25mm below the hinge.

Repeat the process for any required intermediate holes ensuring that the maximum spacing of 600mm is observed.

The fixing holes do not require additional countersinking.

Frame Drilling - Non-Hinge Sides

Place the HDW-Z-02 drill block into the screw channel in the orientation shown. The drill block will locate into the countersink feature of the frame profile.

Position the drill block 35mm above the lower frame corner.
Drill Ø5.00 through the aluminium frame and timber subframe (if fitted).

Repeat the process for all other corners and for any required intermediate holes ensuring that the maximum spacing of 600mm is observed.

The fixing holes do not require additional countersinking.

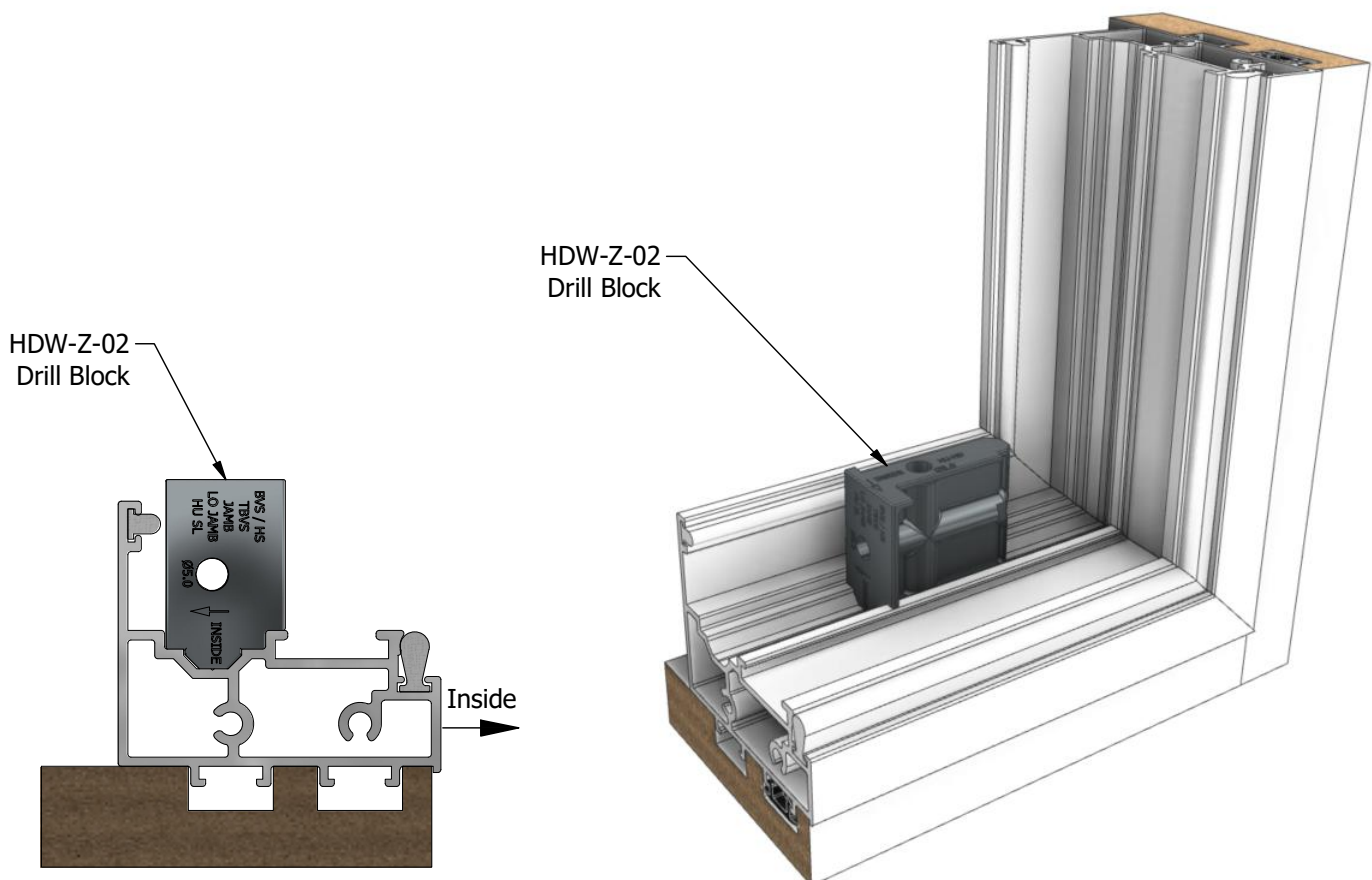



Important - To prevent serious injury, do not open the panel during installation unless it is securely supported.
Note - It is critical that the window is fixed into the reveal as per the instructions on this sheet.
Failure to pack the frame square to the panel will result in poor operation and substandard window performance.

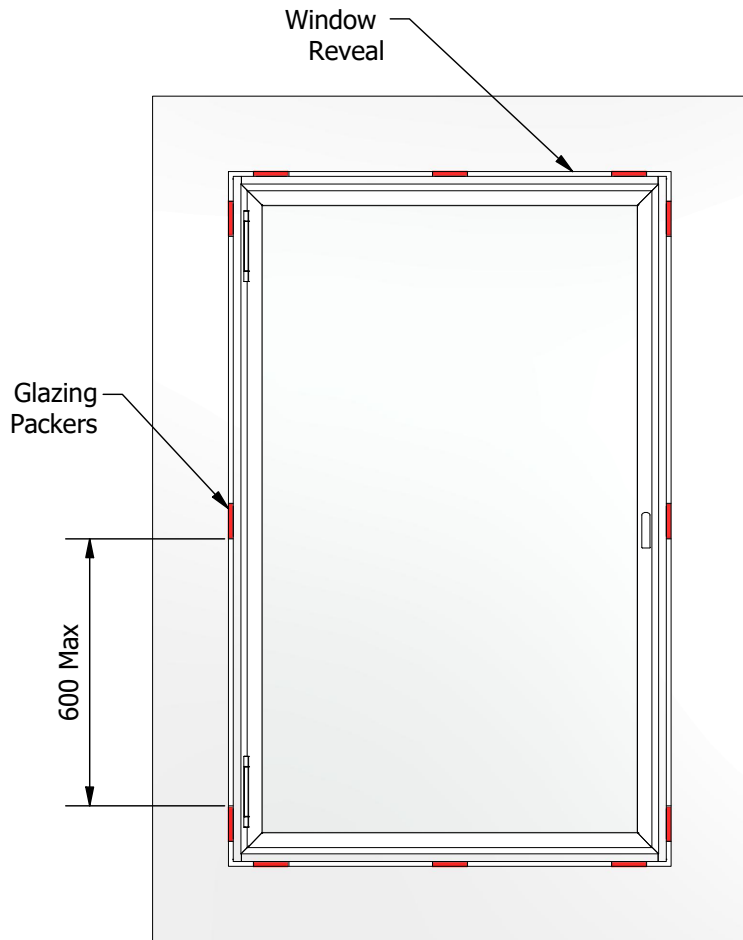

Through Timber Reveal Fix / Through Frame Reveal Fix

For through timber reveal fix windows, the fixing holes are pre-drilled in the factory through the face of the timber behind the outer frame.

For through frame reveal fix windows, it is required to drill fixing holes through the frame as detailed on the following pages of this manual.

HU-SL panels are squared in the factory so it is critical that the outer frame is packed square to the panel as the panel can't be adjusted post installation.

Step 1 - Place window in to reveal.

Step 2 - Use glazing packers to pack both sides of each corner tightly to prevent unwanted window movement during the squaring process.

Step 3 - Add or remove packers one at a time, until the panel has approx. the same gap to the frame at all four corners.

Step 4 - Add additional intermediate packers along all four sides ensuring that all four frame rails are straight to within $\pm 1\text{mm}$.

Face Fix

Face fix windows have fixing holes pre-drilled in the factory through the front face of the timber.

Step 1 - Follow the process for Through Timber / Through Frame fixing as described above ensuring all frame rails are within the acceptable tolerances of straightness.

Step 2 - Open the panel 90° ensuring that it is securely supported for the remainder of the installation process.

Step 3 - Additional packers are also required at the rear between the timber subframe and what it is to be fixed to. The additional packers are required at all fixing positions. Failure to pack the rear of the subframe may result in poor operation of the window.

Final Fix

Step 1 - Carefully open the panel 90° and securely support it ensuring that it is not applying load to the outer frame.

Step 2 - Screw the corners of the frame to the reveal using appropriate screws for the building substrate with a minimum diameter of $\text{Ø}4.5\text{mm}$ and minimum thread engagement of 25mm.

Step 3 - Close the panel and double check that the outer frame to panel gap is still equal around the perimeter. Double check that the run up block does not have to lift the panel more than 1mm. Loosen screws and re-pack the frame corners if necessary until these conditions are met.

Step 4 - Open and support the panel and screw the frame to the building substrate through the remaining intermediate holes.

Side View of Window

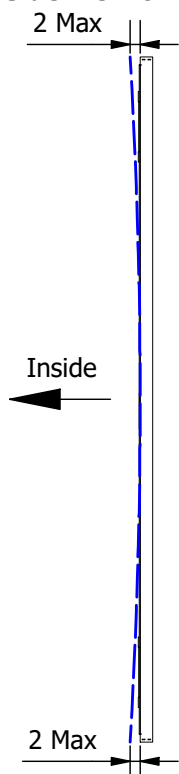

Due to the slimline outer frame profiles of the HU-SL, flatness of the installed window can effect the seal continuity.

If the window is installed with the top and bottom frame corners on the handle side bowed towards the outside of the building, a gap can occur in the seal that prevents ideal sealing of the window.

It is acceptable to set the corners of the handle side of the outer frame so that they bow slightly towards the inside of the building within the 2mm max tolerance shown in the image on the left. This will ensure good seal continuity when the window is in the closed position.

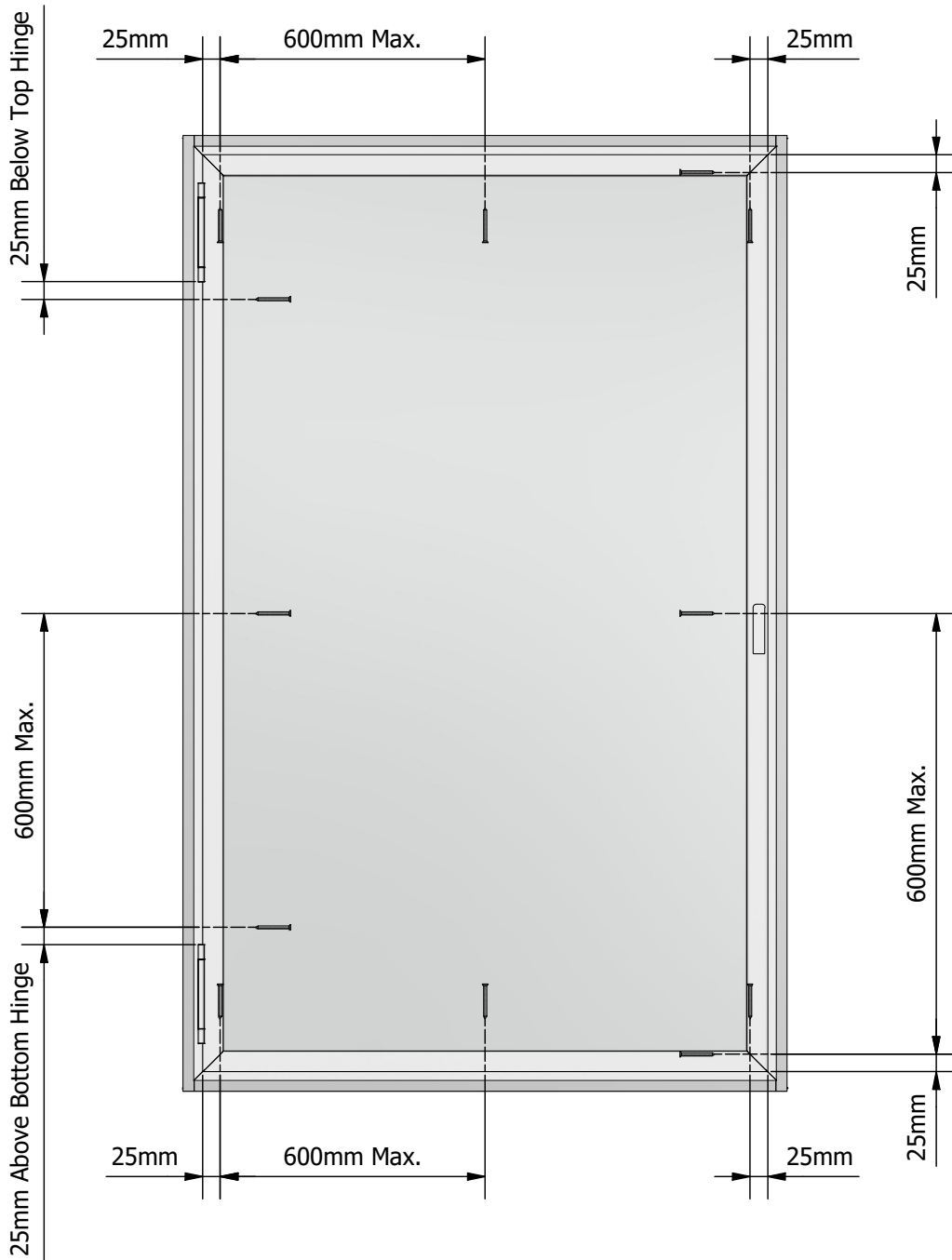

HDW-Z-02 Drill Block

All fixing holes must be drilled through the outer frame using the HDW-Z-02 drill block. This is to ensure that the holes are positioned correctly within the channels. When the drill block is in the correct orientation for the HU-SL window, the face shown in the right hand image will be visible and the arrow will point towards the inside of the building.

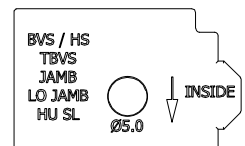



Frame Drilling - Hinge Side

Place the HDW-Z-02 drill block into the screw channel in the orientation shown. The drill block will locate into the countersink feature of the frame profile.

Position the drill block 25mm above the lower hinge.

Drill Ø5.00 through the aluminium frame and timber subframe (if fitted).

Repeat the process for upper hinge with the drill block positioned 25mm below the hinge.

Repeat the process for any required intermediate holes ensuring that the maximum spacing of 600mm is observed.

The fixing holes do not require additional countersinking.

Frame Drilling - Non-Hinge Sides

Place the HDW-Z-02 drill block into the screw channel in the orientation shown. The drill block will locate into the countersink feature of the frame profile.

Position the drill block 25mm above the lower frame corner.

Drill Ø5.00 through the aluminium frame and timber subframe (if fitted).

Repeat the process for all other corners and for any required intermediate holes ensuring that the maximum spacing of 600mm is observed.

The fixing holes do not require additional countersinking.

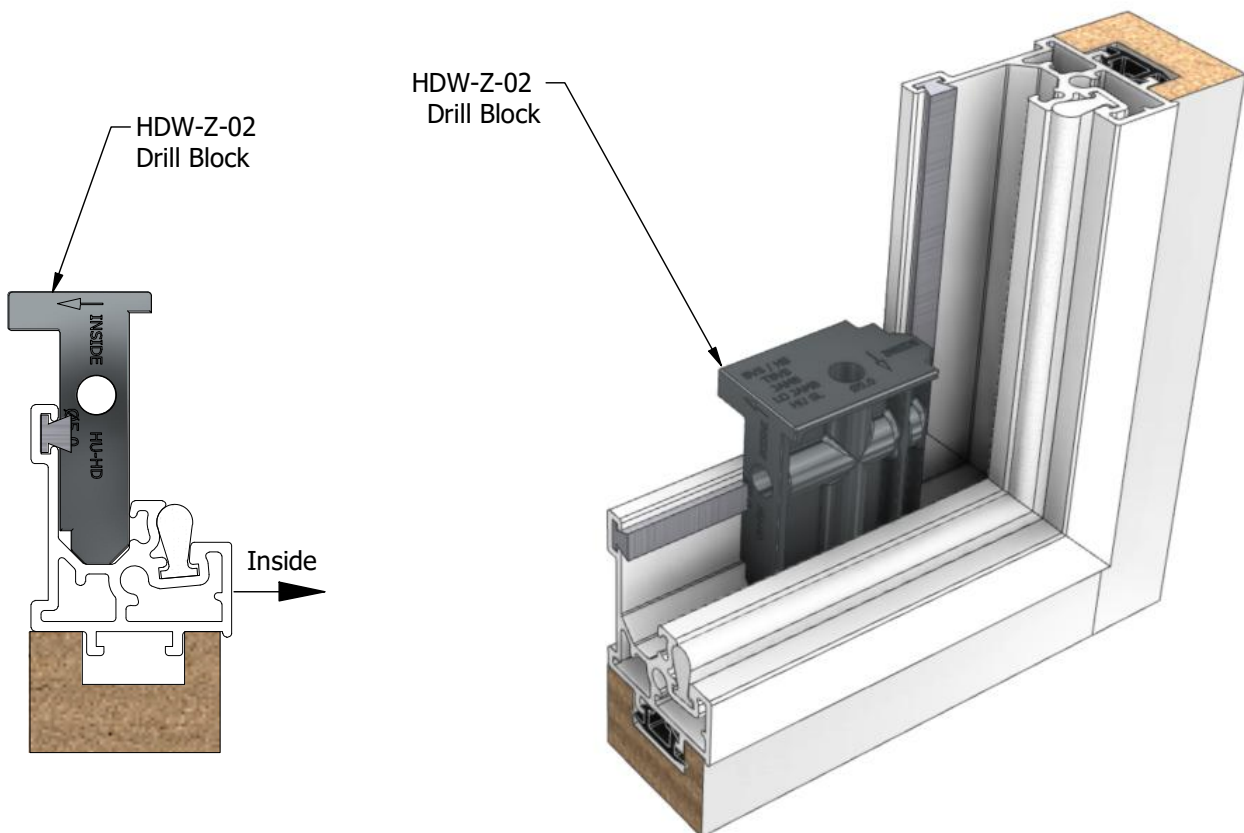



✓

x

General

Panels visually square in outer frame		
Visual condition of paint and glass		

Operation of panels

Handle operates smoothly and releases panel		
Panel opens smoothly with no noise		
Panel closes fully and locks when handle is turned to the locked position		
Key locks and unlocks the handle (HU-HD only)		
Panel does not drop by more than 1mm when opened		
Panel does not catch frame or locking keeps when opened (HU-HD only)		

Comments



Section 5

Lift Out Windows (LO)

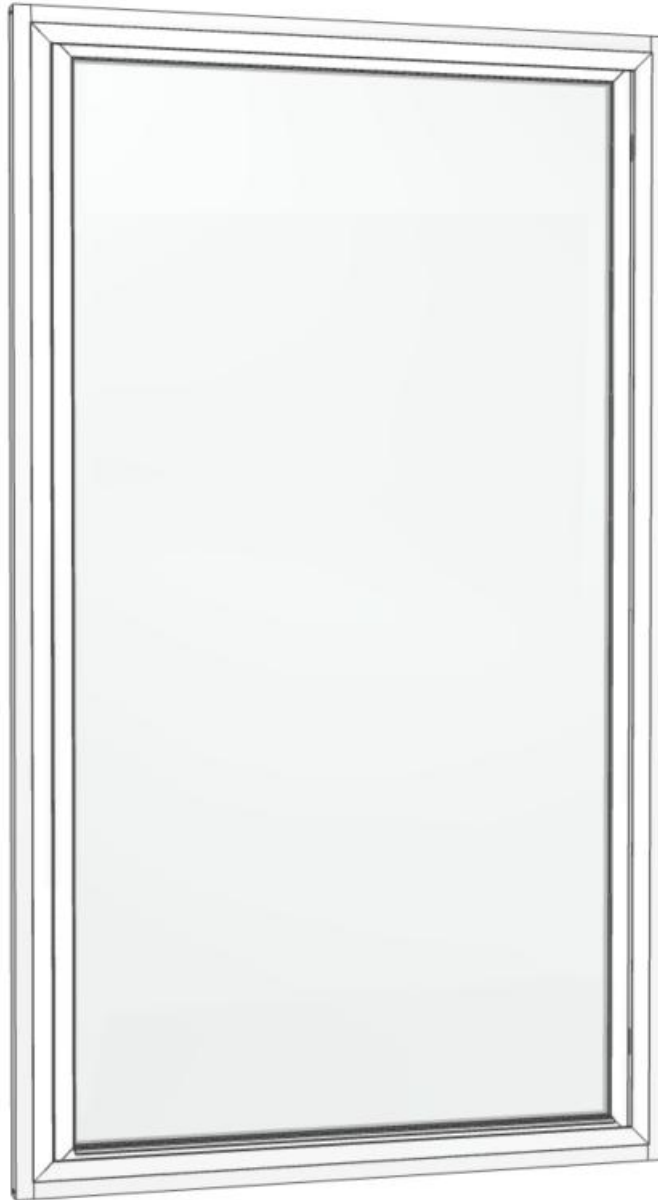

- 5.1 - LO Installation
- 5.2 - LO Through Frame Fixing Hole Positions
- 5.3 - LO Through Frame Fixing Hole Drilling
- 5.4 - LO Post Installation Check List



Note - It is critical that the window is fixed into the reveal as per the instructions on this sheet. Failure to follow these instructions will result in poor operation and substandard window performance.

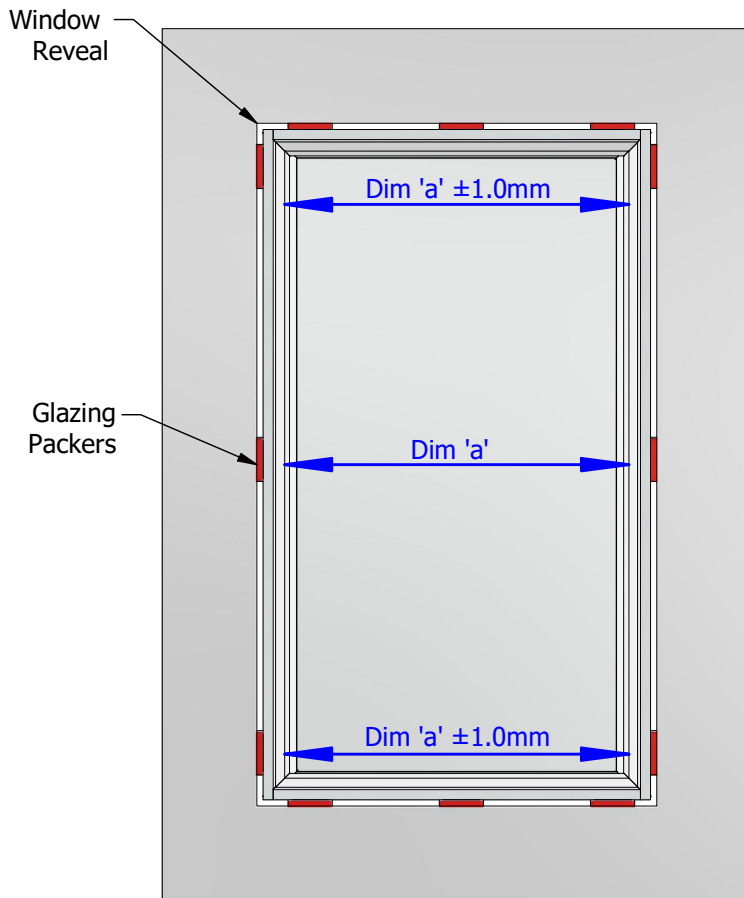

Through Timber Reveal Fix / Through Frame Reveal Fix

For through timber reveal fix windows, the fixing holes are pre-drilled in the factory through the face of the timber behind the outer frame. For through frame reveal fix windows, it is required to drill fixing holes through the frame as detailed on the following pages of this manual.

Step 1 - Place window in to reveal.

Step 2 - Pack the cill level using glazing packers at each screw hole position. If the window only has two fixing holes then an additional central packer should be used.

Cill must be packed level to within $\pm 1.5\text{mm}$.

Step 3 - Pack the jambs using glazing packers at each screw hole location until there is an even gap down both sides between the outer frame and panel.

Jambs must be packed level to within $\pm 1.0\text{mm}$ across their entire length.

The measurement between both frame jambs must be equal for the entire length to within $\pm 1.0\text{mm}$ as shown by dim. 'a' in the diagram

Step 4 - Pack the frame head using glazing packers to ensure that it is not deformed when the head fixing screws are installed.

Head must be packed to within $\pm 1.5\text{mm}$.

Face Fix

Face fix windows have fixing holes pre-drilled in the factory through the front face of the timber.

Step 1 - Follow the process for Through Timber / Through Frame fixing as described above ensuring all frame rails are within the acceptable tolerances of straightness.

Step 2 - Additional packers are also required at the rear between the timber subframe and what it is to be fixed to. The additional packers are required at all fixing positions and flatness across the front of the frame must not exceed $\pm 1.0\text{mm}/1\text{m}$ in any direction.

Failure to pack the rear of the subframe may result in poor window performance.

Final Fix

Step 1 - Remove the panel and screw the frame to the reveal using appropriate screws for the building substrate with a minimum diameter of $\text{Ø}4.5\text{mm}$ and minimum thread engagement of 25mm.

Step 2 - Fit panel in to frame and visually check for equal gap along both sides between frame and panel.

Step 3 - If the gap between the outer frame and panel is not even, remove the panel and loosen the fixing screws. Re-fit the panel and add or remove glazing packers around the frame until the gap between panel and frame is equal both sides. Remove the panel and re-tighten screws once the frame is aligned with the panel.

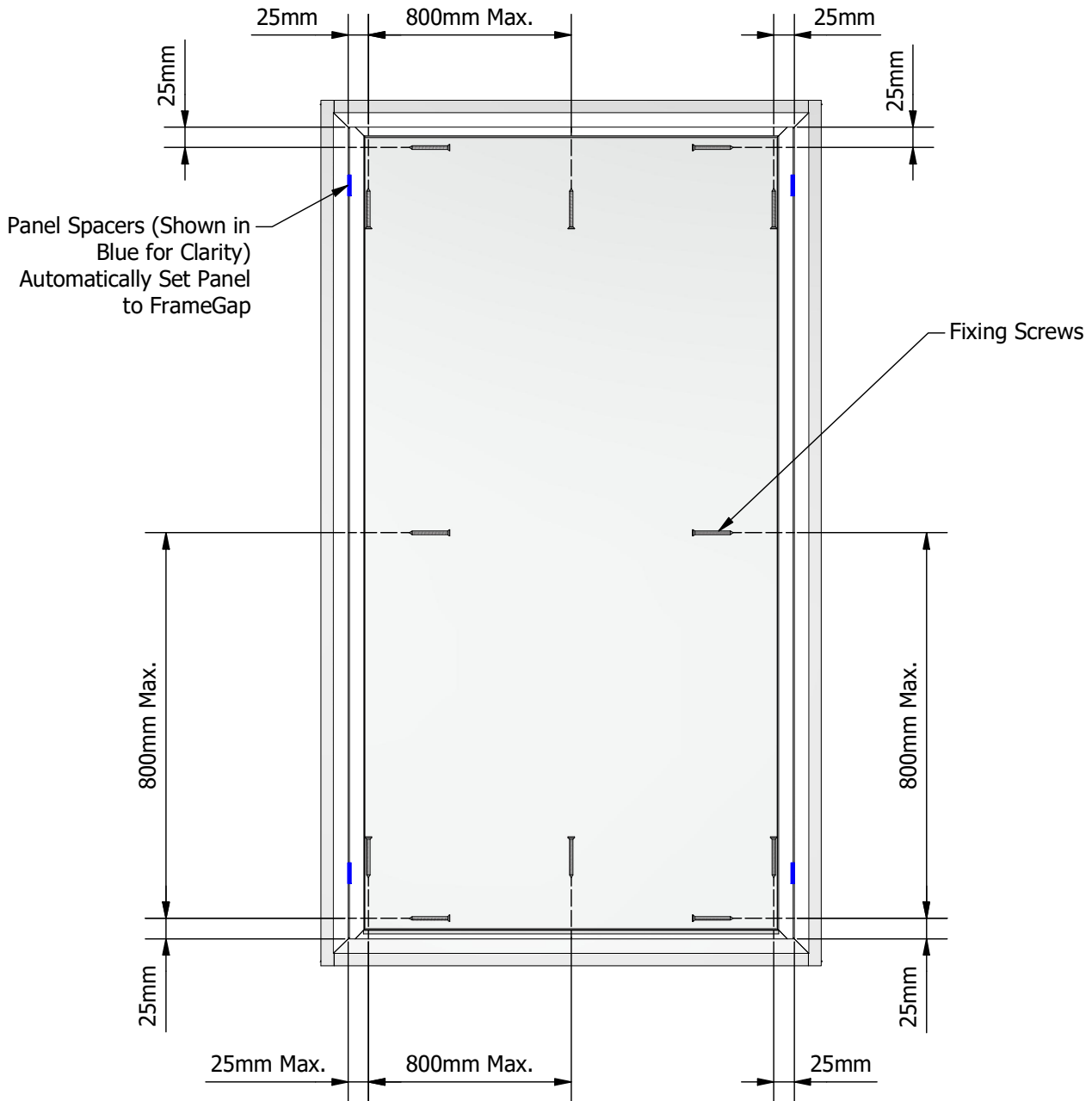

HDW-Z-02 Drill Block

All fixing holes must be drilled through the outer frame using the HDW-Z-02 drill block. This is to ensure that the holes are positioned correctly within the channels.

When the drill block is in the correct orientation for the LO window, the faces shown on the right will be visible and the arrow will point towards the inside of the building.

LO Jamb Orientation

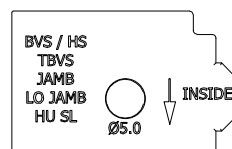

LO Head / Cill Orientation

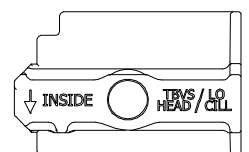



Jamb Drilling

Remove the panel.

Place the HDW-Z-02 drill block into the channel in the orientation shown. The drill block will locate into the countersink feature of the frame profile.

Position so that the first hole is 25mm from the corner.

Drill Ø5.00 through the aluminium frame and timber subframe (if fitted).

Repeat the process for all other jamb corners and any required intermediate holes ensuring that the maximum spacing of 800mm is observed.

The fixing holes do not need additional countersinking.



HDW-Z-02
Drill Block

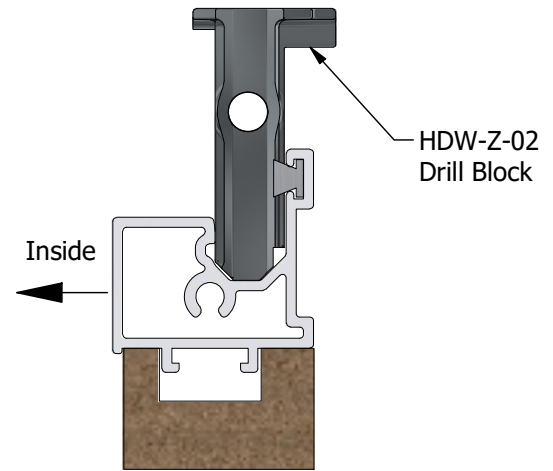

HDW-Z-02
Drill Block

Head / Cill Drilling

Remove the panel.

Place the HDW-Z-02 drill block into the channel in the orientation shown. The drill block will locate between the front and rear walls of the frame profile.

Position so that the first hole is 25mm from the corner.

Drill Ø5.00 through the aluminium frame and timber subframe (if fitted).

Repeat the process for all other head / cill corners and any required intermediate holes ensuring that the maximum spacing of 800mm is observed.

Countersink all holes Ø10mm to ensure that the fixing screws will sit flush with the inside face of the frame.

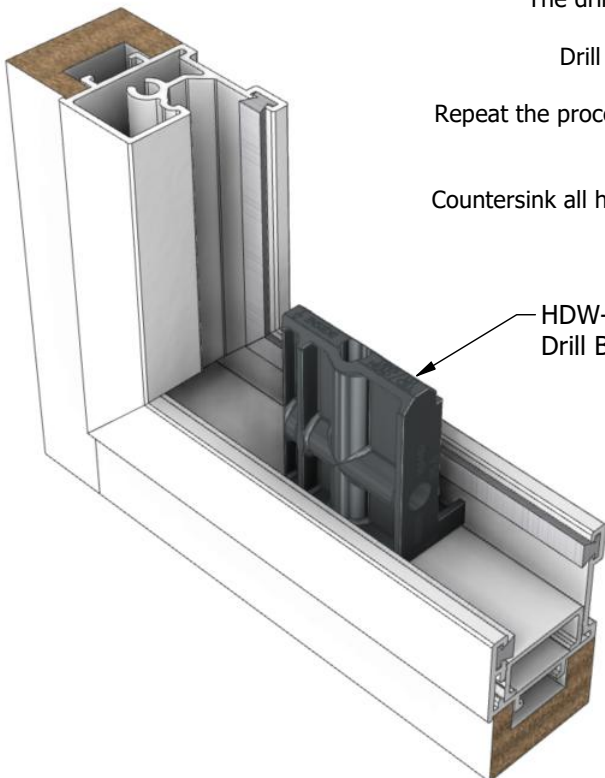

HDW-Z-02
Drill Block

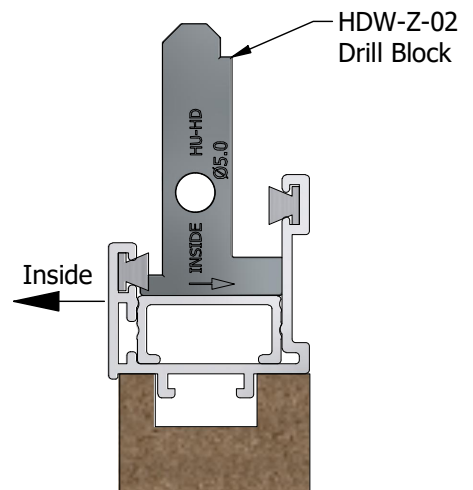

HDW-Z-02
Drill Block



General	✓	x
Panel visually square in outer frame		
Visual condition of paint and glass		

Operation of panels

Panel lifts out easily with no excessive catching on outer frame		
Latches lock successfully when turned 90° (latching option only)		

Comments